



Cateye Ergociser

MODEL EC-1200

OPERATING INSTRUCTIONS



EC-1200 Cateye ergociser

How to Use This Manual

After you read the **Starting up** section of this manual, assemble your Cateye Ergociser™ and try it out . When you get used to the machine and develop a greater interest in it, please read the **Operation** section in preparation to trying the machine's numerous functions. Turn to the **Reference** section whenever the need arises.

Starting up

TABLE OF CONTENTS

1	Assembly -----	6
2	Installing the control unit -----	8
3	How to adjust each part -----	10
4	Your first ride -----	12
5	The five programs of operation -----	14
6	Using your Cateye Ergociser™ without a data card -----	16

Operation

1	Your strength level and training index -----	20
2	Aerobic power measurement (Physical fitness test) -----	24
3	Automatic training -----	28
4	Isopower (constant load) training -----	30
5	Manual training -----	32
6	Hill profile training -----	34
7	How to make a data card -----	36

Reference

1	Handling the pulse (earlobe) sensor -----	40
2	Troubleshooting -----	41
3	Handling/Warranty service -----	42
4	Specifications -----	43

Name of parts

CONTROL UNIT

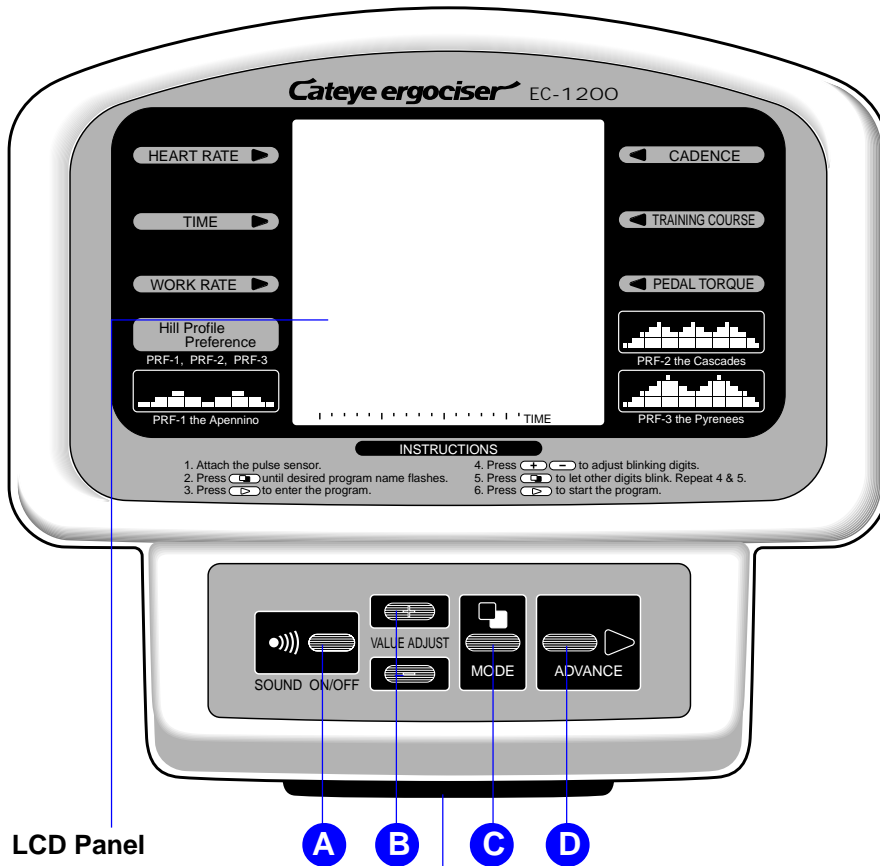

LCD Panel

Card Inlet

A Pitch Sound Button

Turns on or off the pitch sound. When the pitch sound is on, symbol appears on the LCD.

B Value Adjust Button

Before exercise

Increases or decreases the blinking numerical value by 1. (For pedal torque (kg·m) by 0.1)

* When selecting the gender , specifies MALE, and FEMALE)

During exercise

Increases or decreases pedal torque by 0.1kg·m, and the wattage by 5 watts.

C Mode Button

Before exercise

Used to select the program and to change the item of data to input.

During exercise

Displays the elapsed time or the calorie consumption alternatively.

D ADVANCE Button

Makes the program proceed to the subsequent stage.

LCD Panel

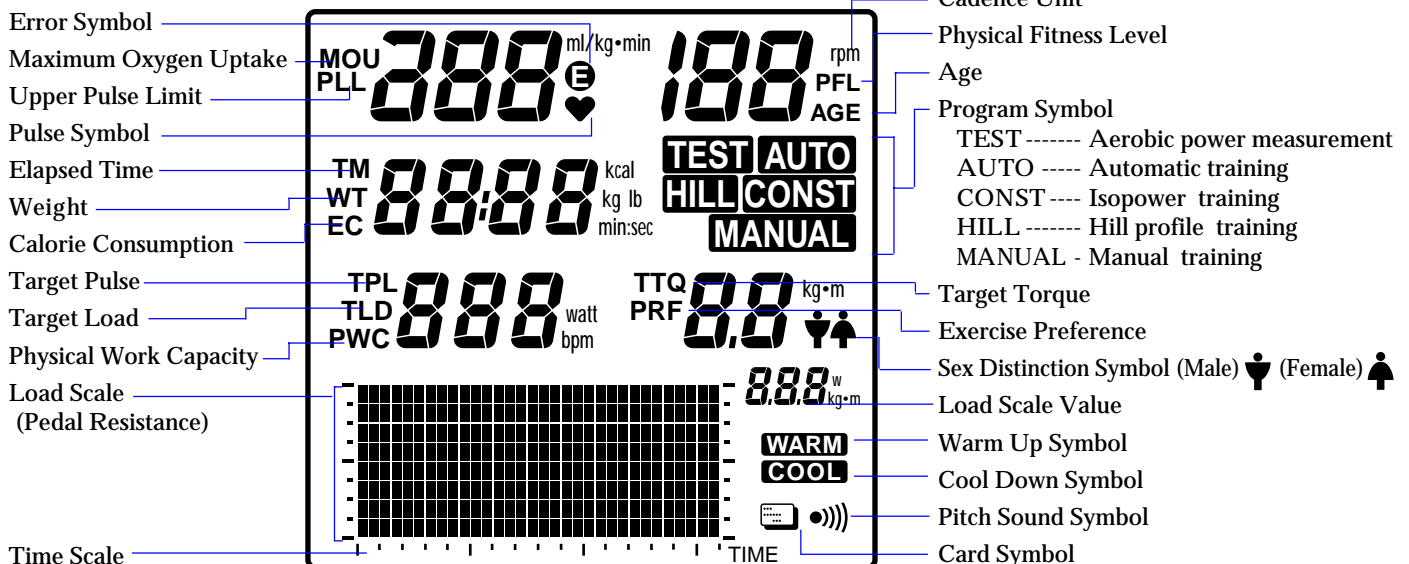

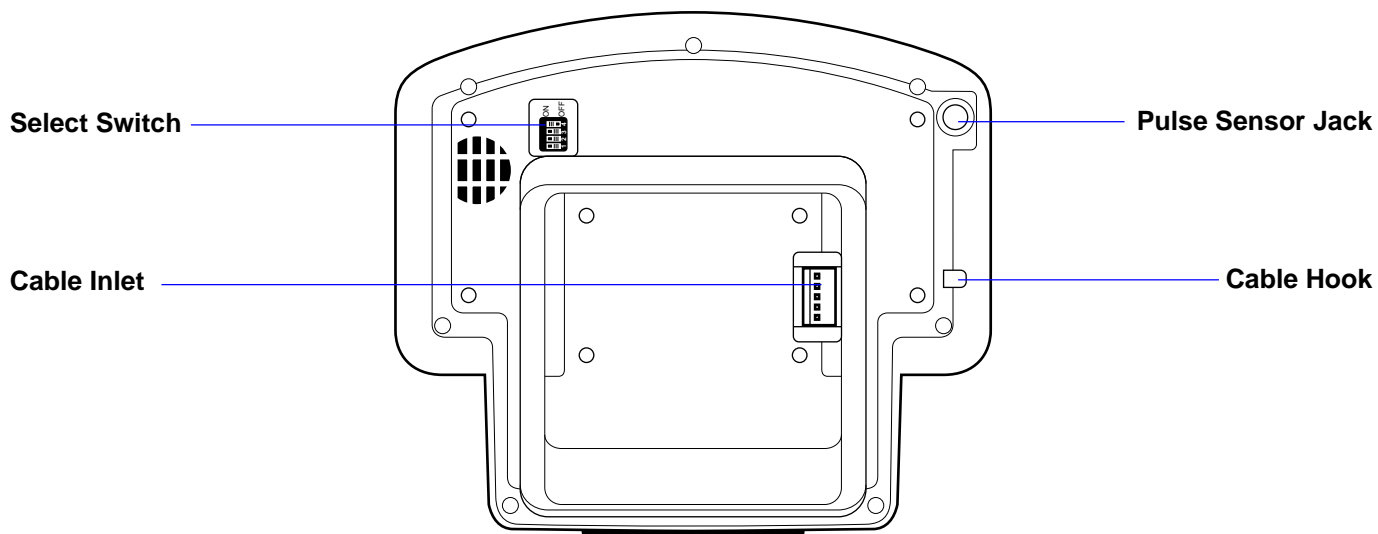

MAIN UNIT

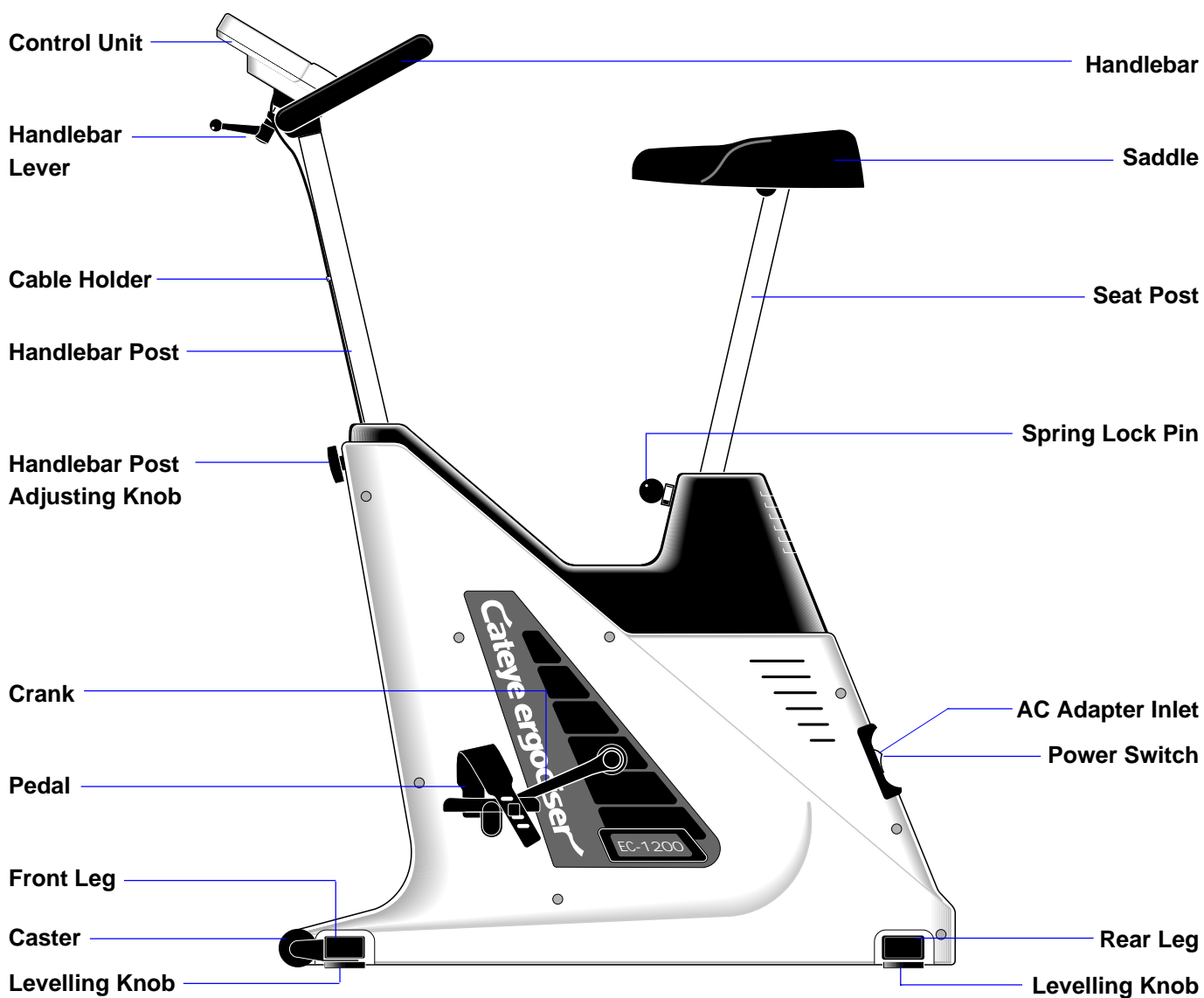

INTRODUCTION

Thank you very much for your purchase of the Model EC-1200 Cateye Ergociser™. The model EC-1200 is a new high-tech exerciser with a built-in computerized training system designed specifically to promote cardiovascular fitness and overall endurance, the keystone of good health. With its endurance test program and four training programs, the EC-1200 will help you to maintain or improve your physical strength in a fun and pleasant way. We hope you will make good use of your Cateye Ergociser™ for years to come.

Before using your new exerciser, please read this manual carefully. Then store it in a safe place along with the warranty card.

FOR SAFE OPERATION

For safe use, always observe the following rules.

1. Before using the EC-1200, it is important to consult a medical specialist if you are suffering from any of the following : heart disease (angina pectoris, myocardial infarction), hypertension, diabetes, respiratory disease (asthma, chronic bronchitis, pulmonary emphysema, etc.), articular metamorphosis, rheumatism, gout, or other diseases and physical complaints. Pregnant women should also consult their doctor before commencing a training program.
2. If you are not used to regular physical activity, it may be dangerous to suddenly engage in strenuous activity. Increase your exercise level gradually.
3. If you feel sick or sense that something is wrong with your body during exercise, stop immediately.

IMPORTANT SAFETY INSTRUCTIONS

Read all instructions before using this exerciser.

DANGER ——— To reduce the risk of electric shock:

1. Always unplug this AC adapter from the electrical outlet immediately after using and before cleaning.

WARNING ——— To reduce the risk of burns, fire, electric shock, or injury to persons:

1. An AC adapter appliance should never be left unattended when plugged in. Unplug from outlet when not in use, and before putting on or taking of parts.
2. Close supervision is necessary when this exerciser is used by, on, or near children, invalids, or disabled persons.
3. Use this exerciser only for its intended use as described in this manual. Do not use attachments not recommended by the manufacturer.
4. Never operate this exerciser if it has a damaged cord or plug, if it is not working properly, if it has been dropped or damaged, or dropped into water. Return the exerciser to a service center for examination and repair.
5. Do not carry this exerciser by supply cord or use cord as a handle.
6. Keep the cord away from heated surface.
7. Never operate the exerciser with the air openings blocked. Keep the air openings free of lint, hair, and the like.
8. Never drop or insert any object into an opening.
9. Do not use outdoors.
10. Do not operate where aerosol (spray) products are being used or where oxygen is being administered.
11. To disconnect, turn all controls to the off position, then remove plug from outlet

This exerciser is intended for both household and commercial use.







This equipment has been certified to comply with the limits for a Class B computing device, pursuant to Subpart J of Part 15 of FCC Rules. Only peripherals (computer input/output devices, terminals, printers, etc.) certified to comply with the Class B limits may be attached to this computer. Operation with non-certified peripherals is likely to result in interference to radio and TV reception.

SAVE THESE INSTRUCTIONS.

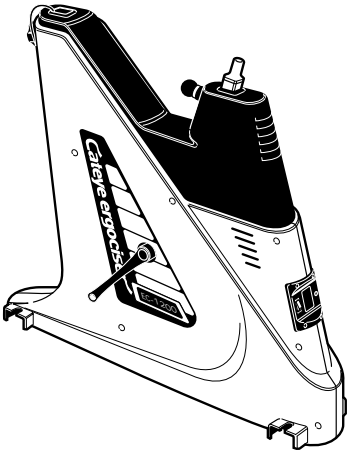
Starting up

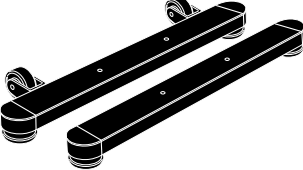
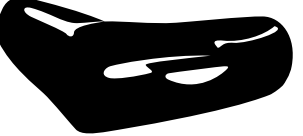
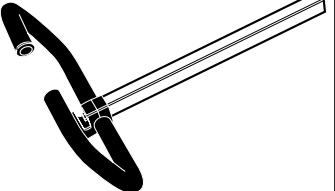
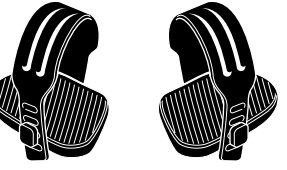
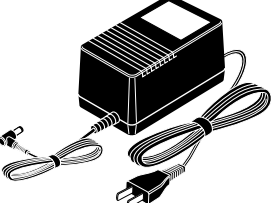
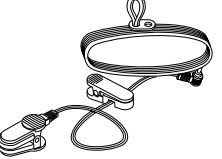
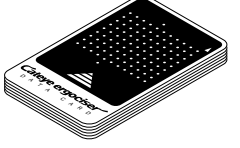
- 1 Assembly
- 2 Installing the control unit
- 3 How to adjust each part
- 4 Your first ride
- 5 The five programs of operation
- 6 Using your Cateye Ergociser™ without a data card

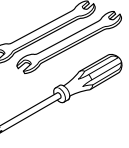
Make sure all components are included in a package.

 <p>Main Body</p>	 <p>Control Unit</p>	 <p>Legs (2 pcs)</p>	 <p>Saddle</p>
 <p>Handlebar & Handlebar Post</p>	 <p>Pedals (L,R)</p>	 <p>AC adapter</p>	
 <p>Pulse Sensor</p>	 <p>Data Card (10) Start Card (1)</p>	 <p>Sensor Clip</p>	 <p>Tools</p>
			 <p>Operating Instructions Warranty Card</p>

Starting up

1 Assembly

1. Attaching the front leg

- Remove the two screws from the respective leg pipes. The one with casters should be used as front leg.
- Place the front leg under the front end of the main body with casters facing forward, and adjust the position so that the screw holes meet the fastening points.
- Fasten the leg with the two screws securely.

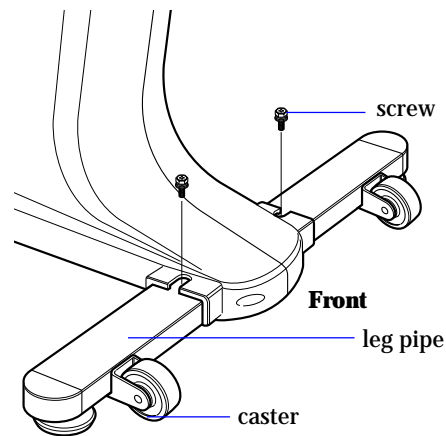

2. Attaching the rear leg

- Place the rear leg pipe under the rear end of the main body, and adjust the position so that the screw holes meet the fastening points.
- Fasten the leg with the two screws securely.

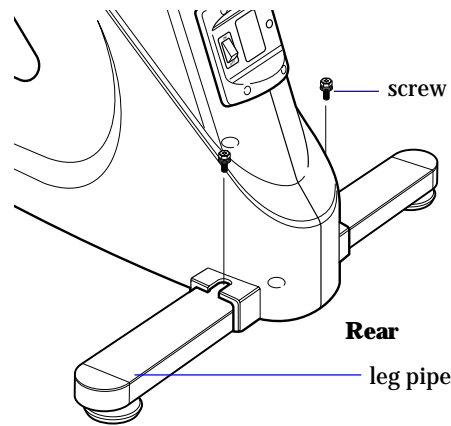

3. Mounting the handlebar post

- Remove the handlebar post knob.
- Insert the handlebar post into the main body, with the post holes facing forward.
- Adjust the handlebar height so that one of the post holes meets the post knob screw hole, and fasten the post knob securely. It will be easier to screw in if you slightly lift the handlebar post.

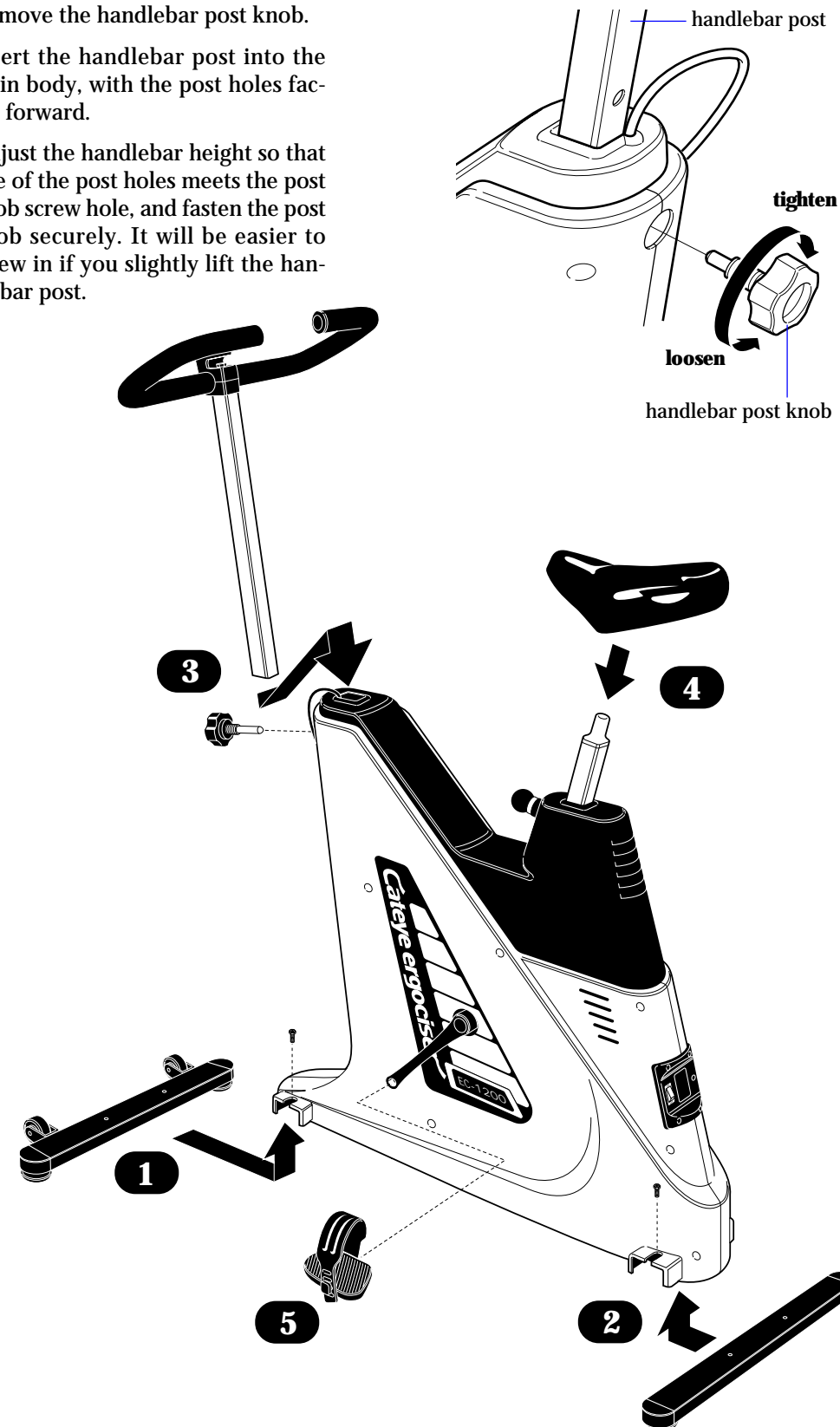

4. Mounting the saddle

- Pull the spring lock pin and lift up the seat post to a proper height for saddle mounting.
- Mount the saddle on the seat post, and use the wrench No.13 provided to tighten both nuts firmly.

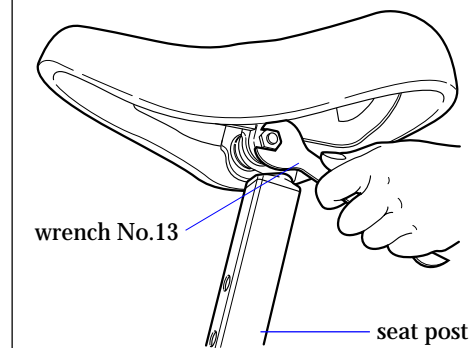

5. Attaching the pedals

- Use the No.15 end of the spanner to attach the pedals firmly to the cranks.
- The right and left pedals are different, so be sure to check for R and L marks.
- Tighten the right pedal by turning clockwise, and the left pedal by turning counterclockwise.

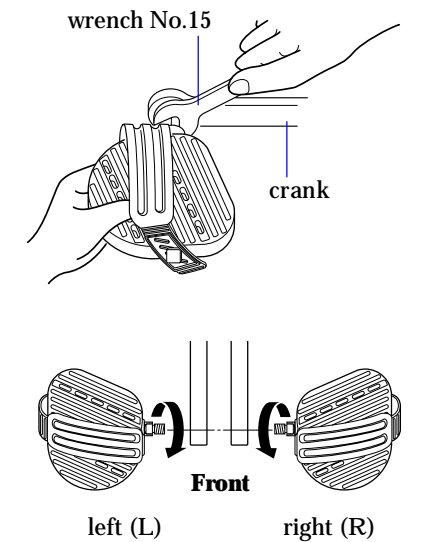

CAUTION: If the pedals are not attached firmly enough to the crank, they can cause an irritating noise. Be sure to attach them firmly.

2 Installing the control unit

1. Strength evaluation table

- By using switches No.1 and 2 in the aerobic power measurement (physical fitness test) program, you can change the internal tables by which your strength is judged.
- When the Model EC-1200 Cateye Ergociser™ leaves the factory, it is set for American use.

1-ON 2-OFF

American use

Evaluation table by AHA Committee: "Exercise testing and training of apparently healthy individuals, A handbook for physicians(1972)"

1-OFF 2-ON

European use

Evaluation table by Dr. Åstrand: "The values from P. -O. Åstrand, Work tests with the bicycle ergometer"

1-OFF 2-OFF

Japanese use

Evaluation table by Dr. Ikegami: "Exercise prescriptions in theory and practice"

2. Units for body weight

- Use select switch No.3 on the back of the control unit to choose kilograms or pounds as your unit of body weight.

NO.3-OFF ----- kg

NO.3-ON ----- lb

CAUTION: When oxygen uptake (VO_2 max) is estimated in the aerobic power measurement (physical fitness test) program, body weight in kg is used. If you mistakenly assume the unit for body, the figure given for oxygen uptake will be wrong by a wide margin.

select switch

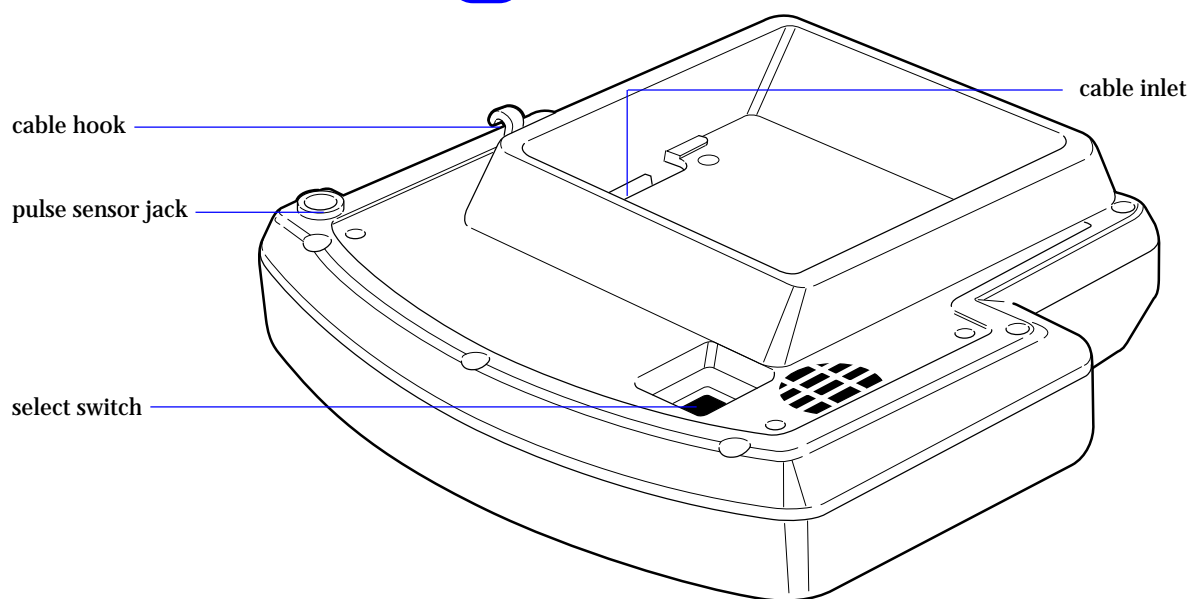
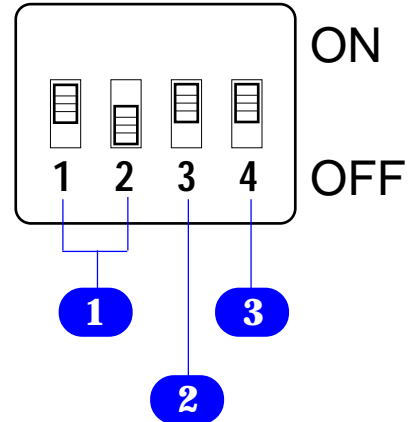

3. Pitch sound setting

- Use the select switch No.4 on the back of the control unit to determine the initial setting of the pitch sound for Aerobic Power Measurement program.

No.4 ON - Pitch sound initial setting is ON

No.4 OFF - Pitch sound initial setting is OFF

Remark: Even if the switch No.4 is set at OFF, you can activate the pitch sound by pressing button on the control unit to light up the symbol in the LCD screen.

4. Installing the control unit

- Insert the cable connector into the cable inlet on the back of the control unit, and cover up the connector with the connector cover.

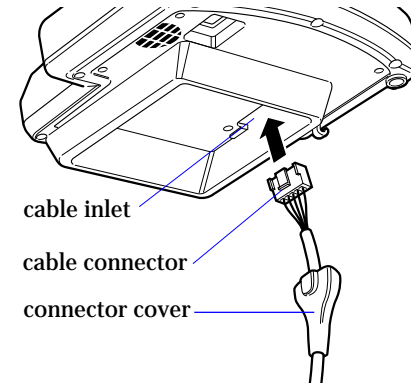

CAUTION: Insert the cable connector until it is firmly locked. The control unit will not function properly with a partial or faulty connection.

- Using the four screws provided, mount the control unit on the handlebar post.

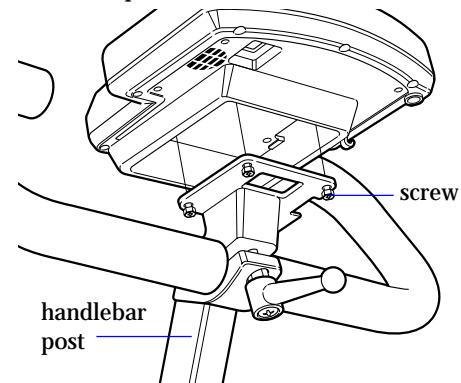

- Insert the cable holder tip into the upper smaller hole on the handlebar post, to hold the cable in place.

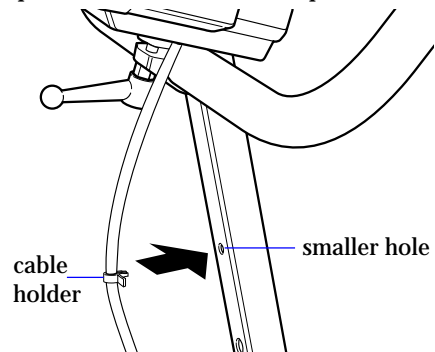

5. Installing the pulse sensor

- Insert the pulse sensor plug into the pulse sensor jack on the back of the control unit, and hang the sensor cable on the cable hook.

- During training, use the sensor clip to take up slack in the cable and keep the cable from moving excessively.

- When you are not using the pulse sensor, attach it to the sensor clip.

- Attach the cable clip to your clothes to keep the cable from swinging around.

CAUTION: Handle the pulse sensor with care. The cable could break if strongly pulled. Pulse sensor lenses need periodic cleaning to remove sweat and oil deposits from skin to work efficiently. Wipe lenses with soft dry cloth.

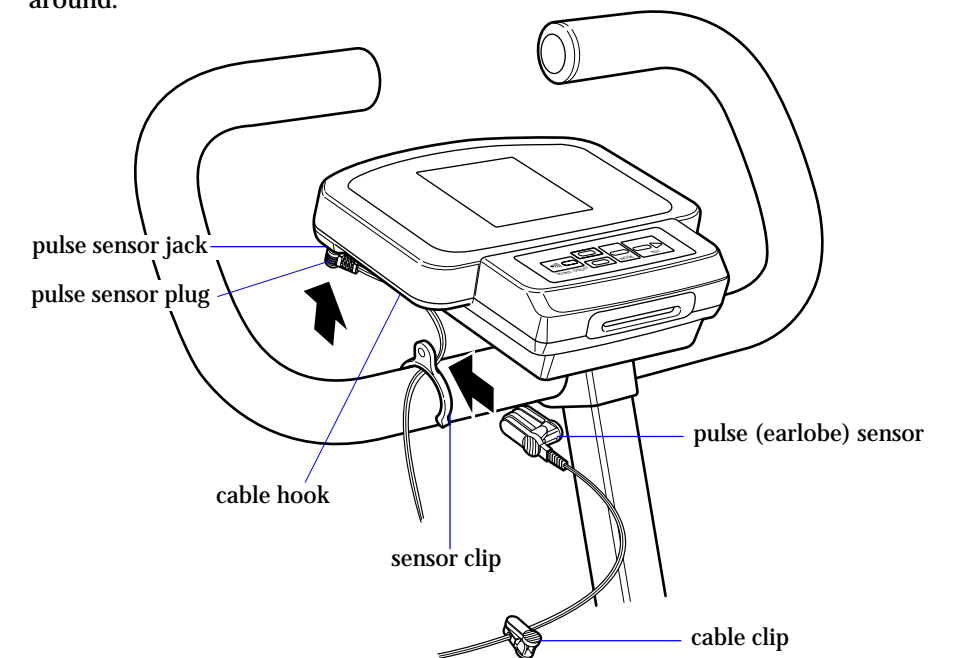

Attaching the pulse (earlobe) sensor

Firmly clip the pulse sensor to the center of your either earlobe. If you are wearing an earring, put it off.



pulse (earlobe) sensor

cable holder

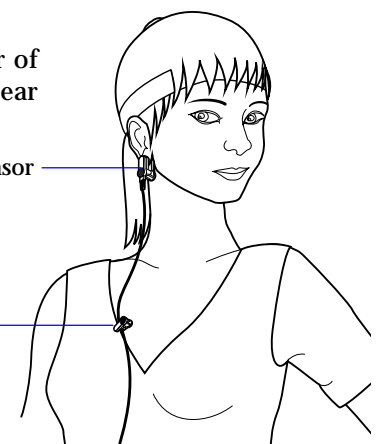

3 Starting up

How to adjust each part

1. Adjusting the saddle height

- Pulling on the spring lock pin will enable you to move the seat post up or down. When the saddle is at the correct level for you, release the knob and move the seat post slightly.
- A spring inside the spring lock pin will drive a pin into the nearest hole in the seat post, locking it in that position.
- The pitch of the seat post holes is 1" (approx. 25mm).

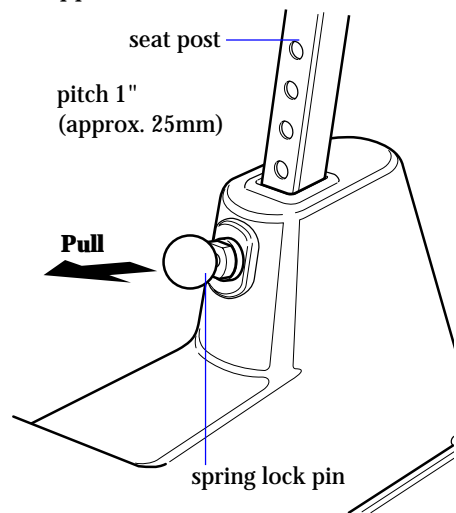

CAUTION: Do not attempt to adjust the saddle height while you are mounted.

2. Adjusting the handlebar height

- Decide the approximate height by one of the 3 holes on the handlebar post, then fix the final position by adjusting the handlebar angle.
- Remove the handlebar post knob.
- Hold the handlebar post where one of the post holes meets the post knob screw hole, and fasten the post knob securely. It will be easier to screw in if you slightly lift the handlebar post.
- The pitch of the handlebar post hole is 3" (approx. 76mm).

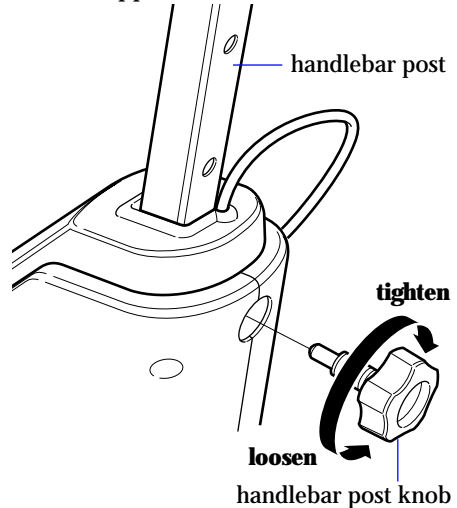

CAUTION: Make sure to grasp the handlebar post firmly when you loosen the handlebar post knob, otherwise it could drop suddenly and damage the unit.

3. Adjusting the handlebar angle

- When you turn the handlebar lever clockwise (when mounted), the handlebar is loosened. The lever turns idle when pulled downward.
- Rotate the handlebar and hold it at the desired angle.
- Turn the handlebar lever counterclockwise to fix the handlebar angle.

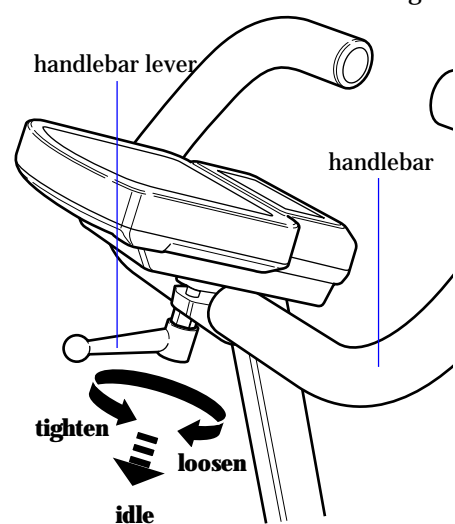

4. Adjusting the pedal belt

- The pedal belt length of the EC-1200 can be adjusted according to your shoes size.

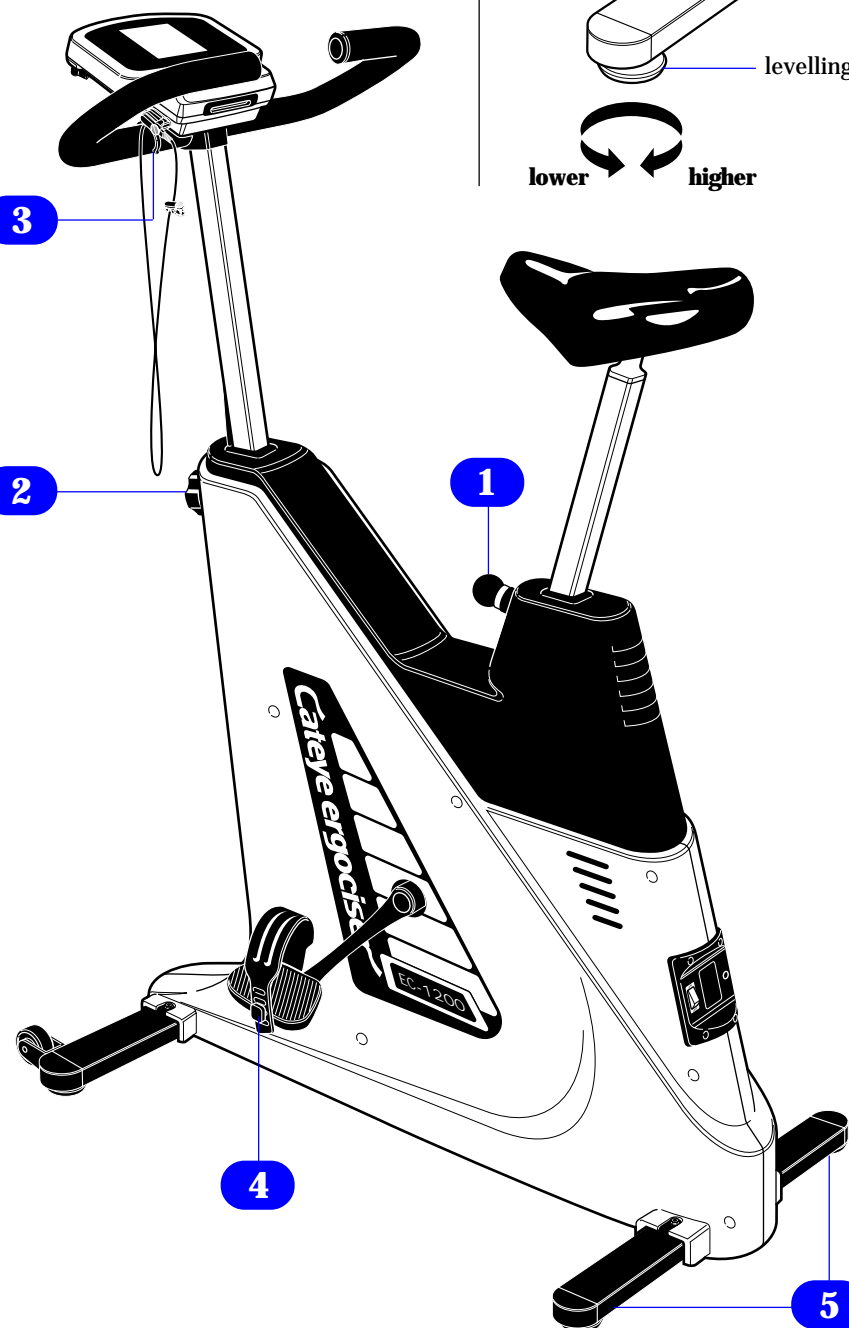

5. The levelling knobs

- Ideally, you should only use your exerciser on a hard, level floor.
- If the exerciser tilts or wobbles during use, turn one or more levelling knobs until a stable position is maintained.

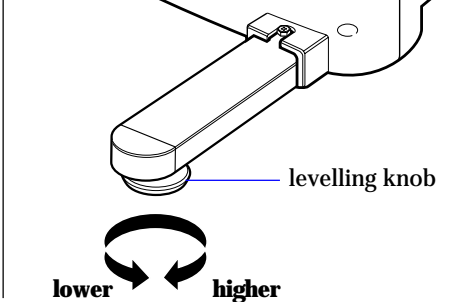

6. Adjusting all parts to fit

- Make various height and angle adjustments so that your posture when seated on the exerciser is like that shown in the diagram below.
- For proper saddle height, your knees should be slightly bent when the pedal is at its lowermost position.
- For proper handlebar height and angle, you should be leaning slightly forward when holding the handlebar.
- When you move the exerciser, lift the saddle and roll the exerciser on its casters.

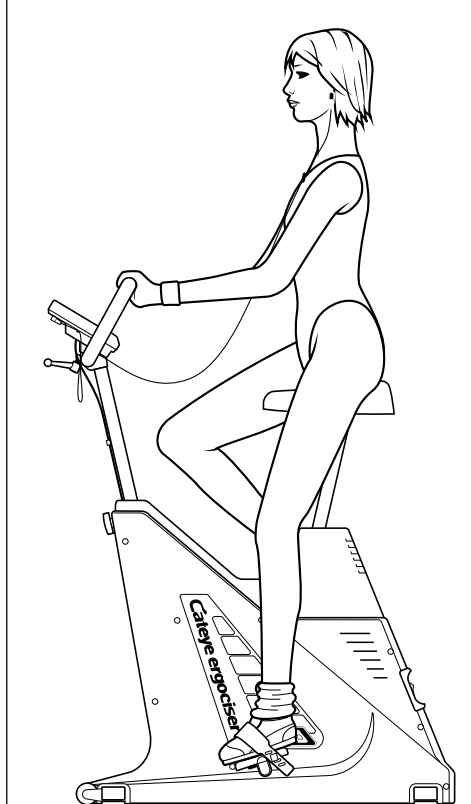

Starting up

Your first ride

1. Turn on power and attach pulse sensor

- Insert the AC adaptor into the AC adapter inlet at the rear of the exerciser.
- Insert the plug of the AC adaptor into any household AC outlet (110-120V).

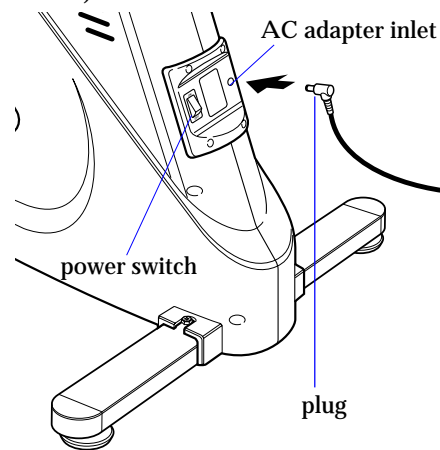

- Turn on power switch. The control unit should make a beep sound and "AUTO" should appear on the screen.

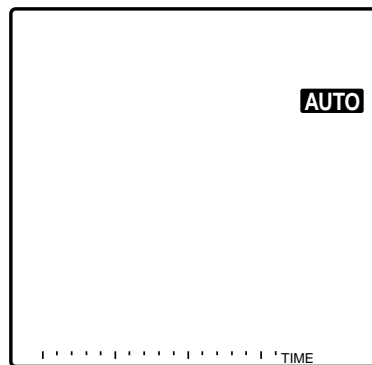

- Attach the pulse sensor to your earlobe. When it is cold, rub your earlobe to facilitate blood circulation before attaching the pulse sensor.

CAUTION: Do not use any AC adaptor other than the one supplied with the Model EC-1200.

2. Insert the start card (red card provided)

- Find the red card (start card) in the packaging of the exerciser. Insert this card into the appropriate slot (card inlet) as shown in the diagram below.

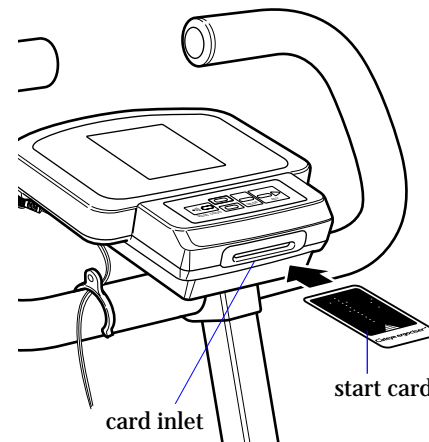

CAUTION: Use only the red card at this stage. It is a sample card with the exercise data already registered in it. The unit will not work with the black cards since they do not contain any data yet.

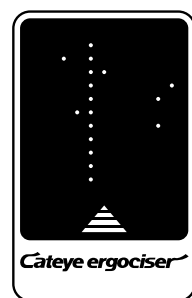

start card

Insert this direction

Remark : You may change data at any time. The **+** and **-** buttons will raise or lower any of the numbers discussed above. Press the **▶** button to move to the next number, which will flash on and off when it is eligible for changing. Now, however, the goal is to get you acquainted with Model EC-1200, so if you change any of the numeral values, please return them to their original setting.

3. Checking the screen display

- The display that appears on the screen should be as described below. If this display does not appear, pull the card out and slowly insert it again. The numbers in the display represent training conditions.

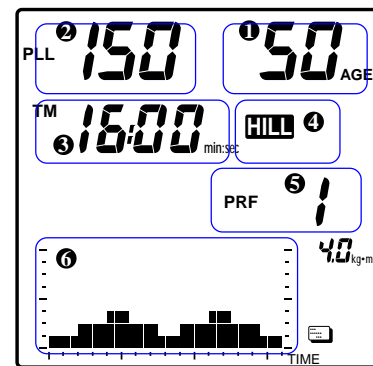

- ① Age is shown by the figure "50"
- ② "150" is the upper-limit pulse rate set by the machine (200 - age). If this pulse rate is exceeded during training, an alarm will sound and the pedal resistance will become to minimum (0.5kg·m).
- ③ Exercise time is shown by "16:00", which means 16 minutes.
- ④ "HILL" which is short for "hill profile training" shows the type of training to be engaged in.
- ⑤ "1" indicates the shape of the hill to be climbed. "1" is the gentlest slope.
- ⑥ Changes of pedal resistance are shown on the graph.

4. Press the **▶** button to start

- Press the **▶** button.
- A display like that in the diagram below will appear on the screen. The numbers on this screen represent your own present condition, and they will change frequently.

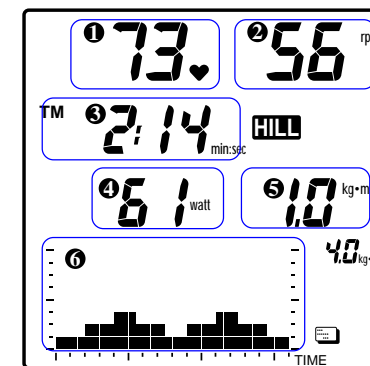

- ① Heartbeats per minute.
- ② Pedal revolutions per minute.
- ③ Elapsed time since start of training session.
- ④ Energy expenditure, expressed in watts. The higher the number, the more energy you are expending.
- ⑤ Pedal resistance. The higher the number, the harder it is to pedal.
- ⑥ As time goes on, the blinking row in the graphic part will shift one by one toward the right hand. According to the position of the blinking row you can find how far you have progressed in the current session.

5. Calorie display

- Pushing the **▶** button gives you the option of viewing a calorie consumption display (calorie consumed from the beginning of the present training session until now) instead of elapsed time.
- Now you are on the exerciser for your first ride. As you train, pedal resistance will change, energy expenditure will change, and your pulse rate will also change. The Model EC-1200 lets you keep track of all this information while you train.

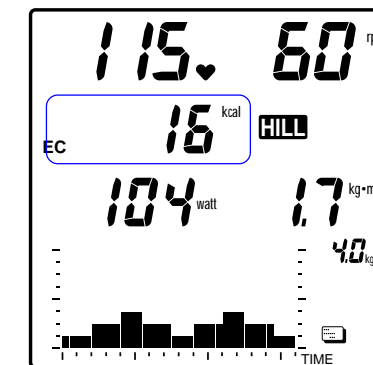

6. When you finish

- When 16 minutes have elapsed, a buzzer will sound and the training session will automatically stop.
- You may stop exercise program at any time during workout by pressing **▶** button twice.
- The liquid crystal display on the screen will return to initial display, "AUTO" alone flashing.
- The Model EC-1200 Cateye Ergociser™ function that we have explained up to this point is only the beginning. Let us move on to an explanation of other functions.

The five programs of operation

1. Aerobic power measurement (physical fitness test)

- Over a period of 10 minutes, you will encounter three different levels of pedal resistance. Your pulse will change in response to the different levels of resistance, and this change in pulse will be used to calculate your overall fitness level, also expressed as MOU (VO₂max). MOU stands for maximum oxygen uptake. The higher your overall fitness level, the greater your endurance.
- Your MOU value is compared with the MOU values of other people who are the same age and sex as you. You are given a physical strength number from 1 to 5 depending on how you rank.
- These results should give you a good idea of your own fitness level and help you to determine what sort of training program will be the most effective for you. For information on how to choose a training program, refer to "Your strength level and training index" on page 20-23 in the **Operation** section on this booklet.



2. Automatic training (training at a constant pulse rate)

- You set the pulse rate at which you want to exercise and the Model EC-1200 automatically adjusts pedal resistance to maintain that pulse rate. This is an ideal basic form of aerobic training.
- As you repeat the exercise at a certain pulse rate and make progress in your fitness level, you will be able to create a greater work intensity under the same pulse rate. Further, you will be able to try exercising at a higher target pulse rate.



3. Isopower training (training at a constant energy expenditure)

- The figure for energy expenditure that is shown on the screen of the Model EC-1200 is calculated from pedal resistance (kg·m) and cadence (rpm).
- In isopower training, you set the desired energy expenditure in watts. The Model EC-1200 takes into account your cadence (rpm) and adjusts pedal resistance (kg·m) automatically so that energy expenditure in watts remains constant.
- This type of training is also called constant load, and is often used in cardio-vascular rehabilitation.

Control range:
cadence: 40~100 rpm
wattage: 25~200 watts

NOTE: If you set your target wattage as under 50 watts, control limit of cadence (rpm) becomes under 100 rpm.



4. Manual training (training at a constant pedal resistance)

- You choose the pedal resistance (torque:kg·m), and it stays constant. This is the most traditional way in which stationary bicycles have been used.

Torque setting range:
0.5~4.0 kg·m
Minimum graduation: 0.1 kg·m



5. Hill profile training (training by cycling up mountains)

- Pedal resistance changes over time to simulate the effect of cycling in the mountains. All changes in pedal resistance are shown on the screen.
- There are three types of mountain profile as follows:
 - PRF-1 the Apennines (Italy)
 - PRF-2 the Cascades (U.S.A.)
 - PRF-3 the Pyrenees (France, Spain)
- The mountain profiles from 1 to 3 are arranged in order of ascending difficulty. Do not strain yourself, but rather enjoy the form of each mountain.
- The initial setting of the exercise time is 16 minutes. You can either increase or decrease the training time, in which case the over all hill pattern will not be changed, but shortened or stretched horizontally in proportion with the designated time.

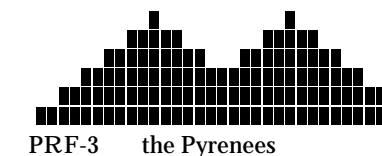
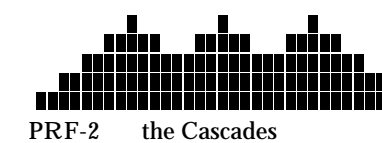
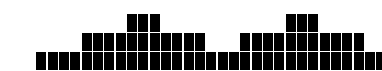

Starting up

Using your Cateye Ergociser™ without a data card

The red card you used on your first ride contains data used in selecting different types of training. Even without this card, you can use buttons on the control unit to run through the same operations.

1. Switch on power supply

- Plug in the AC adaptor and connect to the exerciser. Switch on.
- The screen display will be a flashing "AUTO".

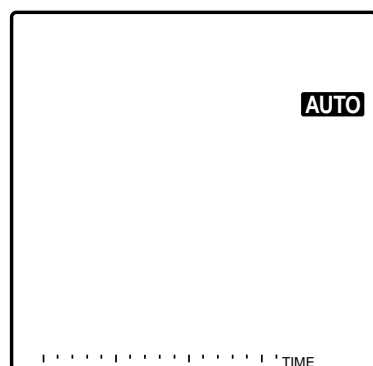

2. Select a training program

- With each press of the button, the flashing indicator moves from one mode to the next in the following order.

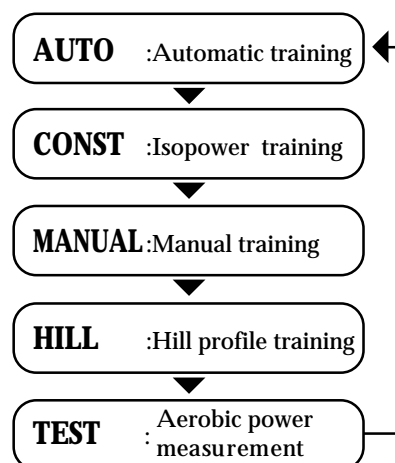

- On your first ride, you tried hill profile training. This time choose "AUTO".
- Push the button until "AUTO" flashes, then push to lock in your choice.

3. Input training conditions

- The screen display will change to the one shown in the diagram here, with the number "40" flashing.

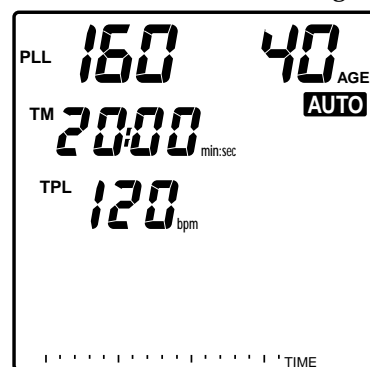

- You can raise or lower the flashing number by pressing either the or button. When or button is held down, the number changes rapidly.
- With each press of the button, the flashing indicator moves from one number to the next in the following order.

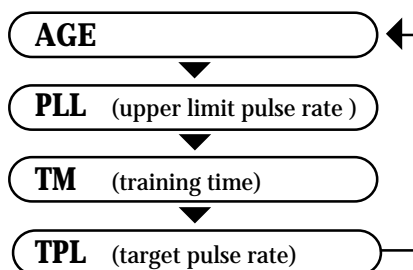

REMARK: Conditions will change according to the training program. Upper limit pulse rate is automatically determined by your age, so there is no need to set this number yourself.

- Let's try changing the displayed target pulse rate from 120 to 115.
- Press the button until "120" is flashing. You want to reduce the number by five, so press the button five times. Has the number changed to "115"?

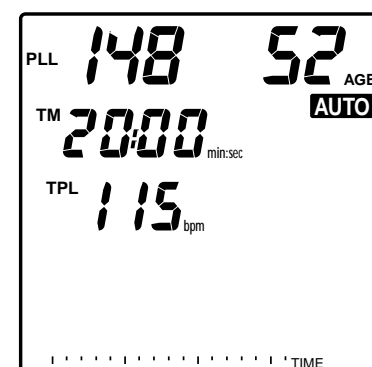

- A card is a tool for setting program choice and training conditions. A card saves you the trouble of setting the same training conditions every time you use the exerciser. For instructions on how to make a card, please refer to page 36, "How to make a data card" in the **Operation** section.

4. Start training

- When you have finished setting training conditions, push the button and start pedaling. The screen display will change as shown below, as time goes on.

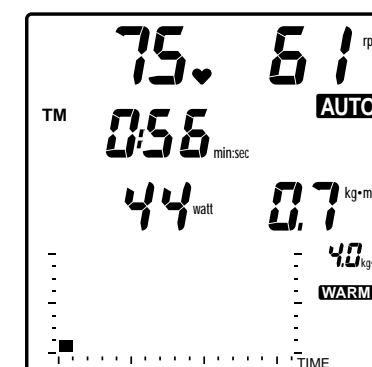

- The automatic training, isopower training and manual training programs all have a warm-up function. Pedal resistance increases slowly until you reach your target pulse rate (Automatic training) or for the first three minutes (all others). While the warm-up function is operating, a **WARM** symbol will remain on the screen.
- By pushing the button, you can switch the display from elapsed time (TM min:sec) to calorie consumption (EC Kcal).

5. At the end of training

- A buzzer will sound when the training time you have set is finished. If you wish, you can continue training even after this buzzer sounds.
- Whenever you want to stop training, before or after the buzzer sounds, push the button once.
- The **COOL** symbol appears on the screen and the pedal resistance drops to the minimum of 0.5 kg-m. This is the cooling down function, which lasts for a maximum of 5 minutes.
- At this stage review your workout data such as time and calorie consumption.

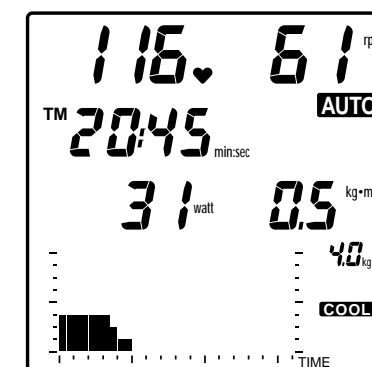

- Press button once again and the program comes to the ultimate end and the display turns to the initial state. (If you stay in the cool down phase for the full five minutes, the program ends automatically with no need to press the button.)
- You should now understand how to use the Model EC-1200 Cateye Ergociser™. Once you get used to the exerciser, you will probably want to refer to the **Operation** section for more detailed information on functions, etc.

Operation

- 1 Your strength level and training index
- 2 Aerobic power measurement
(Physical fitness test)
- 3 Auto matic training
- 4 Isopower (constant load) training
- 5 Manual training
- 6 Hill profile training
- 7 How to make a data card

Your strength level and training index (1)

Purpose of Exercise

- Have you ever been out of breath after climbing a flight of stairs or after a brisk walk? When we are walking, running and even sleeping, our body is taking in oxygen and generating energy. Oxygen taken in by the lungs is sent to the entire body via the circulatory system. If the function of the circulatory system, i.e. aerobic power, is insufficient, we may experience being "out of breath" or experience yet other physical problems.
- We therefore perform "sports for the heart" (aerobic exercise), which causes the heart to work a little more a few times a week, thus increasing the oxygen supply to the body via the circulatory system. The purpose of exercise with the Ergociser is to improve both your physical strength and the functioning of the circulatory system: to improve our aerobic power.

Exercise Plan

- To effectively perform "sports for the heart" and to improve your aerobic power, it is necessary to exercise according to your age and physical fitness. If exercise exceeds your physical fitness level you only injure your body. On the other hand, if the exercise is insufficient, a positive effect cannot be expected.
- The Ergociser EC-1200 has 5 types of computer-controlled programs. One program is the "Aerobic Power Measurement Program". This test program evaluates your physical fitness level, while the other programs are for actual exercise.
- The "Aerobic Power Measurement Program" evaluates your physical fitness level so that you can determine the training index and begin exercise based on the measured result. After exercising for a while (about 3 months), you become aware of the effect on your body. Test your physical fitness level again and gradually set a higher training index, thus maintaining and improving your physical fitness level. A special feature of the Ergociser EC-1200 is that it combines testing with exercise.

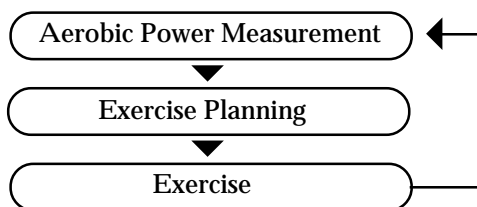

Exercise Frequency and Time

- At least 15 minutes are required for one exercise period, however if possible a 20 ~ 30 minute period is even better.
- To maintain your present condition, exercise at least twice a week, 3 times a week would improve your condition even more. The ideal however is to exercise every day or 5 ~ 6 times a week.

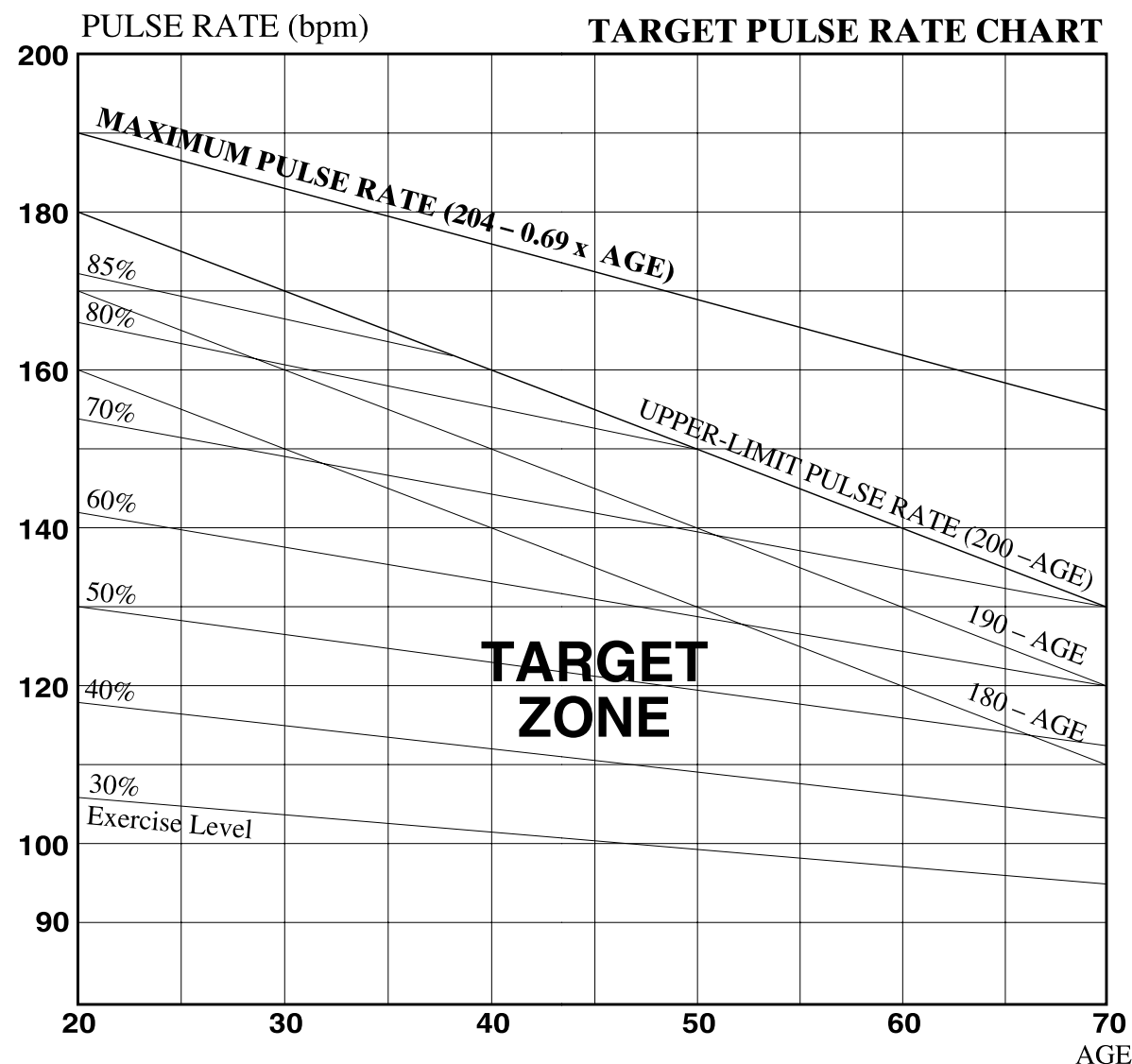

NOTE : You could also determine your target pulse rate more simply by deducting your age from a certain figure. For a beginner, for instance, it is recommendable to start with [160-age (approx. 30~50% depending on your age)], and gradually proceed to higher level such as [180-age (approx. 50~70%)]. It would be ideal to aim at [190-age] eventually.

Glossary of Terms

- **Maximum Heart Rate**
The heart rate increases according to the intensity of exercise, there is however a limit. The maximum heart rate that a person can sustain is called the "maximum heart rate". Generally the heart rate declines as we get older, this differs however between individuals, and is largely due to how much one exercises.
- **Difference Between the Heart Rate and Pulse Rate**
The heart rate is the rate of the heart beat per minute measured by an electrocardiograph. On the other hand, the pulse rate is measured as follows.
1) By palpating an artery near the skin surface, such as the carotid artery, measure the pulse count of a blood vessel.
2) Transmit a sensor light to an earlobe or finger tip, and measure the pulse count via the subtle changes of the sensor light transmission caused by the heart beat.
Although the measurement principle and method are different, both the heart and pulse rates have the same value per minute, and are therefore regarded as synonymous.
Since earlobes move very little during exercise and are not influenced very much by physical movement, it is appropriate to use an earlobe to measure the pulse rate during exercise. The Ergociser EC-1200 therefore measures the pulse rate by detecting changes in the circulation of the earlobe.
- **Pulse Limit**
As a standard maximum heart rate, "220-Age", "204-0.69 x Age", etc. are used. With the Ergociser EC-1200, a somewhat lower value is used: "200-Age". This pulse limit allows a person to safely exercise.
- **Target Pulse Rate**
The pulse rate to maintain during exercise as a target is called the "target pulse rate". In the "Auto training" program, this pulse rate is automatically maintained. However, even with other programs, always be conscious of your target pulse rate during exercise. Refer to the illustration on the left.

Exercise Level Based on the Pulse Rate

The pulse rate increases according to the intensity of the exercise. In other words, the pulse rate during exercise is a barometer for the exercise level. The exercise level can be determined in percentages by the following formula.

$$\text{Exercise Level (\%)} = \frac{\text{Pulse rate during exercise} - \text{Pulse rate at rest}}{\text{Maximum heart rate} - \text{Pulse rate at rest}} \times 100$$

Therefore, if you want to discern the target of the exercise level from the pulse rate (target pulse rate), you can calculate as follows.

$$\text{Target pulse rate} = (\text{maximum heart rate} - \text{pulse rate at rest}) \times \frac{\text{exercise level (\%)}}{100} + \text{pulse rate at rest}$$

Operation 1

Your strength level and training index (2)

Physical Fitness Level and Training Index

The "Aerobic power measurement" program evaluates your physical fitness level according to 5 levels, and it also evaluates your maximum oxygen uptake with an estimated value. Based on the result, you can choose your own training level (program type and exercise intensity) from the following index.

1. Automatic Training

- In this program, the exercise intensity is set by the target pulse rate (beats per minute: bpm). Select your target pulse rate from the following table, based on your age and physical fitness level (PFL) from 1 to 5.
- If the target you select is difficult, reduce the target pulse rate by 10 bpm. You need not work hard from the beginning, continuing is most important.
- This table is arranged so that even people who have not exercised so much can benefit. The targets in this table may be too easy for people who exercise often. If you have confidence, increase your target in 10 bpm units, referring to the target zone in the illustration on page 21.
- Exercise for at least a 15 minute period. If possible a 20 ~ 30 minute period is even better.
- If overweight control (calorie combustion) is the purpose of the exercise, set the target pulse rate lower so that you can easily exercise even while watching TV, but extend your exercise time longer, exceeding 30 minutes.

PFL	20~30s	40~50s	over 60s
1	110 bpm	100 bpm	95 bpm
2~3	120 bpm	110 bpm	105 bpm
4~5	130 bpm	120 bpm	115 bpm

2. Isopower Training

- In this program the exercise intensity is set by the work rate: wattage. Select the target wattage from the table shown below, according to your PWCmax. value provided by the Aerobic Power Measurement.
- If the selected wattage proves too hard for you, try again at the level 10 watts lower. When it becomes easy enough, raise the target by 10 watts.
- Exercise for at least a 15 minute period. If possible a 20 ~ 30 minute period is even better. Since warm up takes 3 minutes, set your actual exercise time to "actual exercise time + 3 minutes".

PWCmax	Target Wattage	PWCmax	Target Wattage
100 watt	40 watt	220 watt	90 watt
120 watt	50 watt	240 watt	95 watt
140 watt	55 watt	260 watt	105 watt
160 watt	65 watt	300 watt	120 watt
180 watt	70 watt	350 watt	140 watt
200 watt	80 watt	400 watt	160 watt

3. Manual Training

- In this program, the exercise intensity is set by the pedal resistance (torque: kg.m.).
- Exercise for at least a 15 minute period. If possible a 20 ~ 30 minute period is even better. Since the warm up takes 3 minutes, set your exercise time to "actual exercise time + 3 minutes".

PWCmax	Pedal Torque(kg.m)		
	50rpm	70rpm	90rpm
120 watt	0.9	0.7	0.5
140 watt	1.1	0.8	0.6
160 watt	1.2	0.9	0.7
180 watt	1.4	1.0	0.8
200 watt	1.6	1.1	0.9
220 watt	1.7	1.2	1.0
240 watt	1.9	1.3	1.1
260 watt	2.0	1.5	1.1
280 watt	2.1	1.6	1.2
300 watt	2.3	1.7	1.3
350 watt	2.7	1.9	1.5
400 watt	3.1	2.2	1.7

4. Hill Profile Training

- Merely select one of the 3 patterns of this program. Try different hill profiles (shape of the mountain) in a range where you don't feel too much difficulty. The exercise intensity can also be adjusted by pedaling slower or faster depending on the changes of pedal resistance.
- First, choose the most suitable preference (PRF) according to your PWCmax value, from the table shown below.
- The exercise time is initially set as 16 minutes, but you can revise it down to minimum 3 minutes or up to 99 minutes.

PWCmax	140 watt	195 watt	240 watt
Exercise Pattern(PRF)	1	2	3
Calorise Consumption	75 Kcal	110 Kcal	120 Kcal

- The calorie consumption provided above is based on the cadence of 60 rpm and the exercise time of 16 minutes. The calorie expenditure will vary in proportion with the pedal cadence and the exercise time.

Aerobic power measurement (1)

1 Select the Aerobic Power Measurement Program

- For program selection see the **Starting up** section page 16.

2 Input Conditions

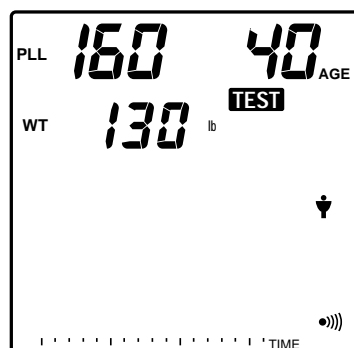

- Input your age, pulse limit, weight and sex. The initial display prior to input is as in the drawing. The numeric for age is blinking.

Initial	Value	Setting Range
Age	40	10~ 99
Pulse Limit	160 bpm	80~ 180 bpm
Weight	130 lb	
Sex	Male	

- The pitch sound to adjust your cadence at 60 rpm (rings every half second) is set "ON".
- There is no graphic display yet in the LCD.
- Press the button to change the blinking numeric.
- You can increase or decrease the blinking numeric by pressing the button.

3 Start Program

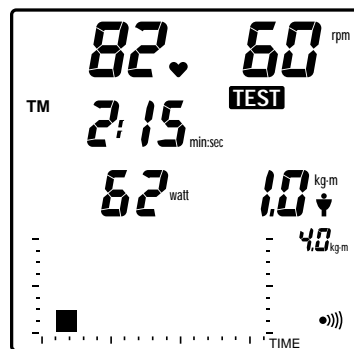
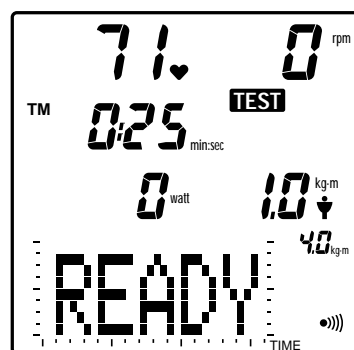

- Press the button after you set the conditions.
- The LCD changes as in the drawing.
- Wait calmly for one minute. Meantime "READY" is displayed in the graphic part of the LCD.
- After one minute has elapsed, the buzzer sounds and the pitch sound begins. Then start pedaling according to the pitch sound.

Note: You can cancel the pitch sound by pressing the button. If the symbol is on the LCD, the pitch sound is ON, if not displayed, pitch is OFF. Pressing the pitch sound button toggles ON/OFF.

- The initial workload (pedal torque) is indicated in dot(s) in the graphic part of the LCD. One dot along the horizontal axis indicates 30 seconds, and one along the vertical axis 0.5 kg-m. At every 30 seconds, the row of dots will increase by one towards the right of the graphic display, with the last dots blinking.
- At the 4th and 7th minutes the pedal torque will increase depending on your pulse rate at that time. The increased torque of 2nd and 3rd stages will be indicated in dots time after time in the graphic part.

4 Test Result Display, Cool Down

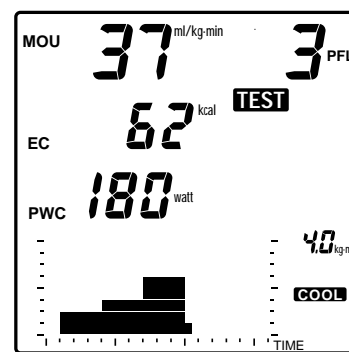

- The buzzer sounds at ten minutes and the test result is displayed on the LCD. The program then enters the 5 minutes cool down phase and the **COOL** symbol shows up, while the LCD keeps displaying the test result, along with the calories consumed during the test. If you keep pedaling during the cool down period, only the EC (Calorie Consumption) will be updated, while all other data remain fixed.
- Review and record the test result on a memo at this point, before the screen turns blank.

Note: If the upper pulse limit alarm is activated and the workload drops to the minimum within 4 minutes after starting pedaling, the test result is not displayed. But if the upper pulse limit is activated after 4 minutes of pedaling, your aerobic power is estimated based on the progress up to that point only, and the approximate result is displayed.

5 End Program

- If the 5 minute cool down phase elapses or if you press the button, the buzzer sounds and the program ends.
- The LCD returns to the initial screen.
- If you are completely finishing the exercise, be sure to turn the power off by the switch at the rear of the main body.

Aerobic power measurement (2)

Physical Fitness Level (PFL)

- There are five physical fitness levels: 1 ~ 5. These levels are relative evaluations that compare your maximum oxygen uptake (MOU), estimated by the aerobic power measurement program, with the values of other people of the same age and sex (Physical Fitness Level Test Table).
- Ergociser EC-1200 stores the following physical fitness level test table, which can be selected by the selector switch on the back panel of the control unit. (See page 8)

Physical Fitness Level Test Table by Maximum Oxygen Uptake (MOU)

- 5: Excellent
- 4: Good
- 3: Average
- 2: Fair
- 1: Poor

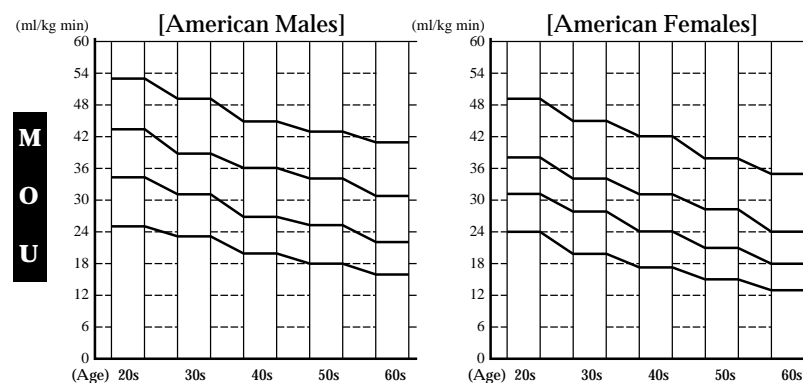

Maximum Oxygen Uptake (MOU)

- MOU is widely used as an index for total physical endurance. MOU indicates the amount of oxygen one can intake at the limit of their physical work capacity. In the Ergociser EC-1200, MOU is calculated based on the maximum physical work capacity (PWC max.) explained below, assuming that
1 litre of oxygen corresponds to 5.0 Kcal, and the human efficiency rate for a bicycle exercise is 23%

Maximum Physical Work Capacity (PWC max.)

- In the Ergociser EC-1200 "Aerobic power measurement" program the weight of the pedals are changed at 3 levels, and the pulse rate at the end point of each level is measured. Based on the result, the relationship between the work rate (wattage) and the pulse rate is analyzed by linear regression. Extend the regression line until reaching the maximum heart rate (=204-0.69 x age) which is estimated by age. The work rate (wattage) of this point becomes the maximum physical work capacity.
- PWC max. safely estimates how much exercise is possible at the limit of physical work capacity, that is, at maximum heart rate without performing actual exercise.

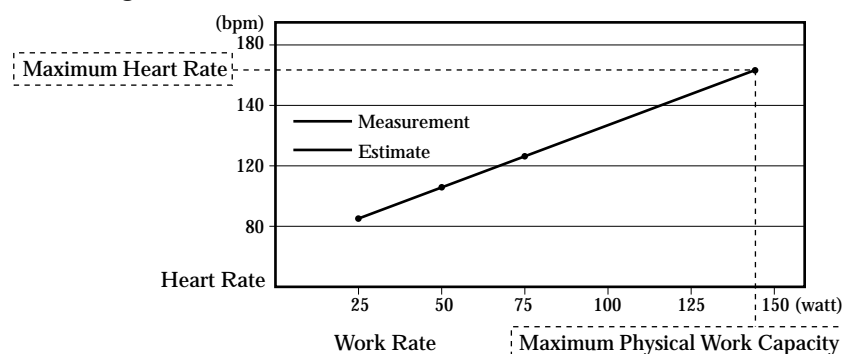

Test Protocol

- In the "Aerobic power measurement" program of the EC-1200, the workload (pedal resistance:torque) for the subsequent stage is determined depending on your pulse rate at the previous stage. The workload (pedal resistance:torque) will be increased along one of the routes illustrated below, depending on your pulse rate TM during the program.
- The pulse rates specified below represent the protocol for a person of 20 years. For the people over 20, the borderline of pulse rate will be adjusted by the age adjustment coefficient (K), which is obtained by the following formula:

$$K = \frac{204 - 0.69 \times \text{Age}}{204 - 0.69 \times 20}$$

- For people over 60 years, the coefficient (K) is calculated as 60.

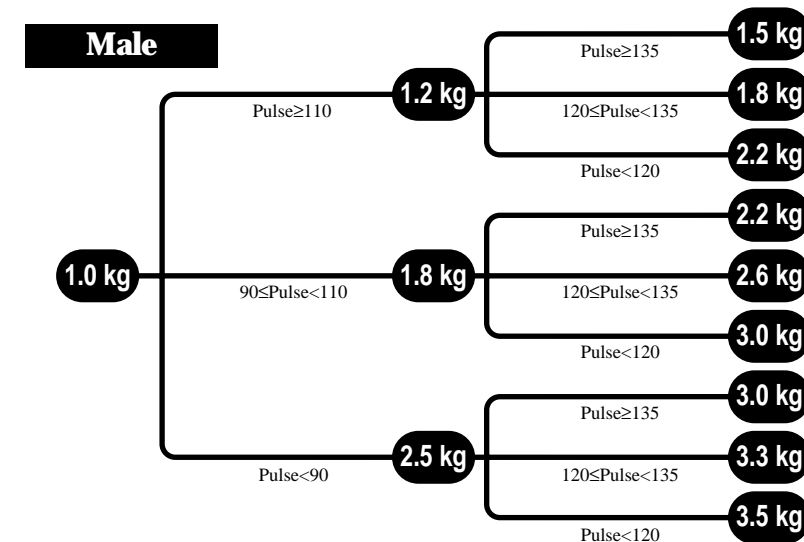

Remark: The load change for males over 50 years of age is the same as for females.
When the age is less than 20, the load changes as if the age were 20.

Operation

Automatic training

1 Select the Automatic Training Program

- For program selection see the **Starting up** section page 16.

2 Input Conditions

- Input age, pulse limit, exercise time and the target pulse rate. The initial display before input is as in the drawing, with the numeric for age blinking.

	Initial Value	Setting Range
Age	40	10~ 99
Pulse Limit	160 bpm	80~ 200 bpm
Exercise Time	20 min	0~ 99 min
Target Pulse Rate	120 bpm	60~ 180 bpm

- The pitch sound to adjust your cadence at 60 rpm (rings every half second) is set "OFF".
- There is no graphic display yet in the LCD.
- Press the button to change the blinking numeric. You can increase or decrease the blinking numeric by pressing the buttons.

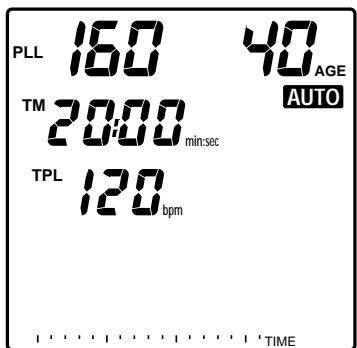

3 Start Program

- Press the button to start the program after you set the conditions.

4 Start Warm Up

- The LCD changes as in the drawing.
- The initial workload (pedal torque) is indicated in dot(s) in the graphic part of the LCD. One dot along the horizontal axis indicates 30 seconds, and one along the vertical axis 0.5 kg-m. At every 30 seconds, the row of dots will increase by one towards the right of the graphic display, with the last dots blinking.
- The pedal resistance increases gradually, so that the pulse rate comes closer to the target pulse rate.
- The **WARM** symbol remains until your pulse rate gets close to the target pulse rate.

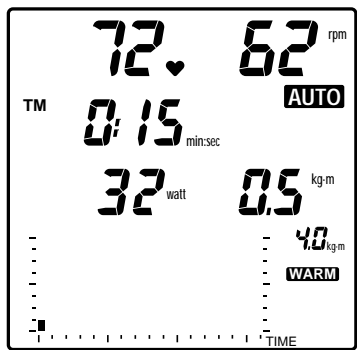

5 Exercise Maintaining the Target Pulse Rate

- After the **WARM** symbol has gone out, during exercise every time the pulse rate digresses ± 3 beats/min from the target, the load changes 0.1 kg-m, keeping your pulse rate close to the target pulse rate.

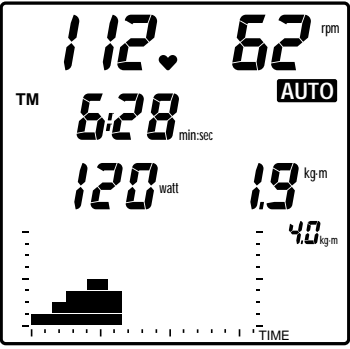

Note: When the pulse rate is "0" (when the earlobe sensor is removed) or when the pedal cadence is "0" (when not exercising) the pedal resistance does not change.

Remark 1: You can increase or decrease the pedal resistance by pressing the buttons.

Remark 2: The graphic part can display the torque pattern for 16 minutes at maximum, except in Hill Profile program. If you set a longer exercise time, the graphic part becomes full at 16 minutes, then at every additional 30 seconds the torque pattern of the latest 16 minutes will be updated on the screen.

6 Finish Exercise Cool Down

- The buzzer sounds at the specified time. If you press the button, the program enters a 5 minute cool down phase and the **COOL** symbol lights up, then the pedal resistance becomes the minimum of 0.5 kg-m.

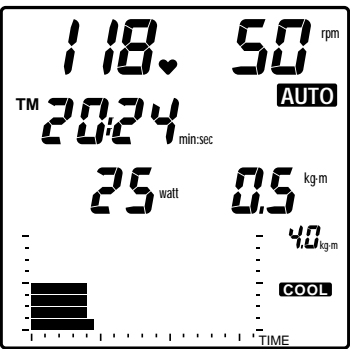

Note: Even if the buzzer sounds the program does not enter the cool down phase unless you press the button.

- The LCD still displays the contents during exercise.
- Review your workout data such as time and calorie consumption displayed, using the button.

7 End Program

- If the 5 minute cool down phase has elapsed or if you press the button, the buzzer sounds and the program ends. The LCD returns to the initial screen.
- If you are completely finishing the exercise, be sure to switch off the main body.

4 Operation

Isopower (constant load) training

1 Select the Isopower Training Program

- For program selection see the **Starting Up** section page 16.

2 Input Conditions

- Input age, pulse limit, exercise time and set wattage. The initial display prior to input is as in the drawing. The numeric for age is blinking.

	Initial Value	Setting Range
Age	40	10~ 99
Pulse Limit	160 bpm	80~ 200 bpm
Exercise Time	20 min	0~ 99 min
Set Wattage	60 watts	25~ 200 watts

- The pitch sound to adjust your cadence at 60 rpm (rings every half second) is set "OFF".
- Press the button to change the blinking numeric. You can increase or decrease the blinking numeric by pressing the buttons.

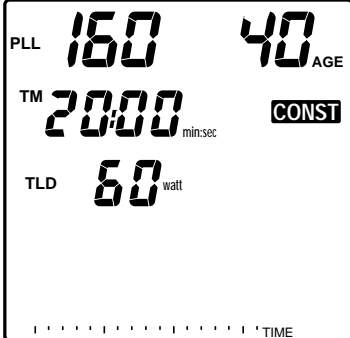

3 Start Program

- Press the button to start the program after you set the conditions.

4 Start Warm Up

- The LCD changes as in the drawing.
- The initial workload (pedal torque) is indicated in dot(s) in the graphic part of the LCD. One dot along the horizontal axis indicates 30 seconds, and one along the vertical axis 0.5 kg-m. At every 30 seconds, the row of dots will increase by one towards the right of the graphic display, with the last dots blinking.
- During the 3 minute warm up, after starting exercise, the pedal resistance gradually increases and the **WARM** symbol is shown.

NOTE: During the warm up, the pedal resistance is increased so as to reach the set wattage in 3 minutes provided you pedal at 50 rpm. If you pedal faster than 50 rpm and reach the set wattage earlier than 3 minutes, the warm up is finished at that moment.

Remark: If you first press the , and holding it down press the button to start the program, instead of just pressing the button, you can skip the warm up phase and start the exercise at the preset wattage from the scratch.

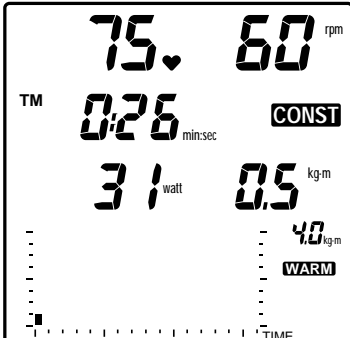

5 Exercise at Constant Wattage

- After the **WARM** symbol goes out, the pedal resistance (torque kg-m) increases or decreases according to the pedal cadence. During exercise the pedal resistance (torque: kg-m) changes in 0.1 kg-m units to maintain the set value for wattage.

Note: For calculation purposes, pedal cadence under 40 rpm is regarded as 40 rpm, and pedal cadence over 100 rpm is regarded as 100 rpm.

Remark 1: In this program the target wattage can be revised during the exercise by 5 watts with each press of the buttons. In such case the revised target wattage is displayed for 2 seconds in place of the current wattage.

Remark 2: The graphic part can display the torque pattern for 16 minutes at maximum, except in Hill Profile program. If you set a longer exercise time, the graphic part becomes full at 16 minutes, then at every additional 30 seconds the torque pattern of the latest 16 minutes will be updated on the screen.

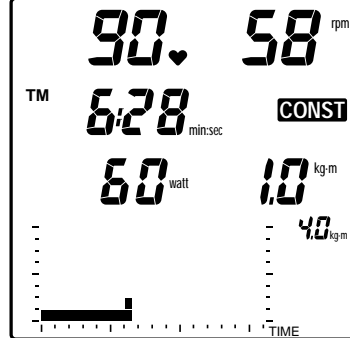

6 Finish Exercise Cool Down

- The buzzer sounds at the specified time.
- If you press the button, the program enters a 5 minute cool down phase and the **COOL** symbol lights up. Then the pedal resistance becomes the minimum 0.5 kg-m.

Note: Even if the buzzer sounds, the program does not enter the cool down phase unless you press the button.

- The LCD still displays the contents during exercise.
- Review your workout data such as time and calorie consumption displayed, using the button.

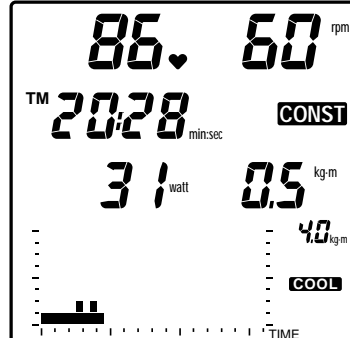

7 End Program

- If 5 minutes of cool down have elapsed or if you press the button, the buzzer sounds and the program ends. The LCD returns to the initial screen.
- If you are completely finishing the exercise, be sure to switch off the unit.

Operation

5 Manual training

1 Select the Manual Training Program

- For program selection see the **Starting up** section page 16.

2 Input Conditions

- Input age, pulse limit, exercise time, and the setting torque value. The initial display prior to input is as in the drawing. The numeric for age is blinking.

	Initial Value	Setting Range
Age	40	10 ~ 99
Pulse Limit	160 bpm	80 ~ 200 bpm
Exercise Time	20 min	0 ~ 99 min
Set Torque Value	1.0 kg-m	0.5 ~ 4.0 kg-m

- The pitch sound to adjust your cadence at 60 rpm (rings every half second) is set "OFF".
- Press the button to change the blinking numeric.
- You can increase or decrease the blinking numeric by pressing the buttons.

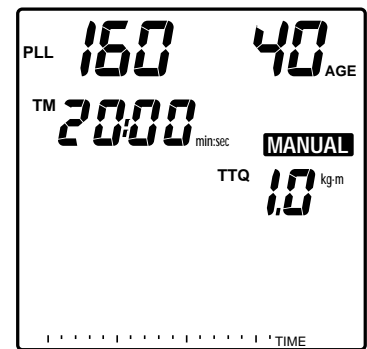

3 Start Program

- Press the button to start the program after you set the conditions.

4 Start Warm Up

- The LCD changes as in the drawing.
- The initial workload (pedal torque) is indicated in dot(s) in the graphic part of the LCD. One dot along the horizontal axis indicates 30 seconds, and one along the vertical axis 0.5 kg-m. At every 30 seconds, the row of dots will increase by one towards the right of the graphic display, with the last dots blinking.
- After starting exercise, during the 3 minute warm up, the pedal resistance gradually increases and the **WARM** symbol is shown.

Note: During warm up the pedal resistance increases so that the set torque value is reached in 3 minutes. If you have increased the torque value to more than the set torque value by pressing the buttons, warm up ends at that point.

Remark: If you first press the button, and holding it down press the button to start the program, instead of just pressing the button, you can skip the warm up phase and start the exercise at the preset pedal torque from the scratch.

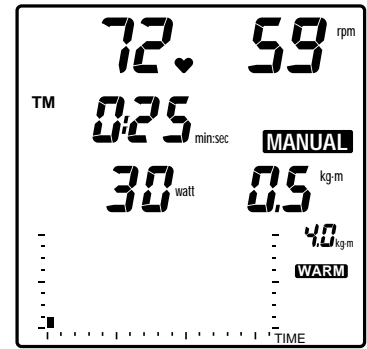

5 Exercise

- Exercise with the set pedal resistance (torque, kg-m).

Note: In this program, you can increase or decrease the pedal resistance by pressing the buttons.

Remark: The graphic part can display the torque pattern for 16 minutes at maximum, except in Hill Profile program. If you set a longer exercise time, the graphic part becomes full at 16 minutes, then at every additional 30 seconds the torque pattern of the latest 16 minutes will be updated on the screen.

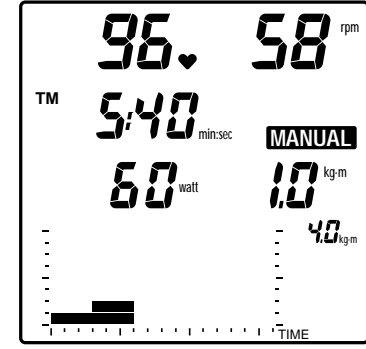

6 Finish Exercise Cool Down

- The buzzer sounds at the specified time.
- If you press the button, the program enters a 5 minute cool down phase and the **COOL** symbol lights up, then the pedal resistance becomes the minimum 0.5 kg-m.

Note: Even if the buzzer sounds, the program does not enter the cool down phase unless you press the button.

- The LCD still displays the contents during exercise.

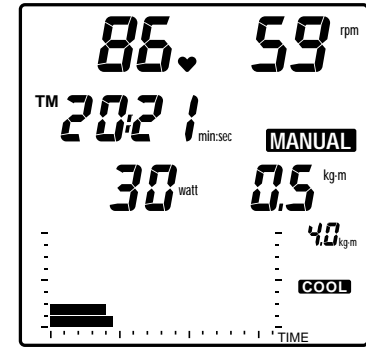

7 End Program

- If the 5 minute cool down phase elapses or if you press the button, the buzzer sounds, the program ends.
- The LCD returns to the initial screen.

06 ation

Hill profile training

1 Select the Hill Profile Training Program

- For program selection see the **Starting up** section page 16.

2 Input Conditions

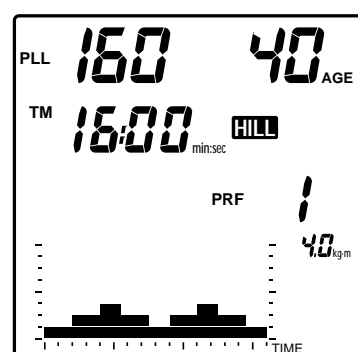

- Input pulse limit, exercise time, and the exercise pattern. The initial display prior to input is as in the drawing. The numeric for age is blinking.

	Initial Value	Setting Range
Age	40	10 ~ 99
Pulse Limit	160 bpm	80 ~ 200 bpm
Exercise Time	16 min	3 ~ 99 min
Exercise pattern	3	1 ~ 3

- The pitch sound to adjust your cadence at 60 rpm (rings every half second) is set "OFF".
- The screen will display the over all hill pattern of the selected number.
- Press the button to change the blinking numeric.
- You can increase or decrease the blinking numeric by pressing the buttons.

3 Start Program

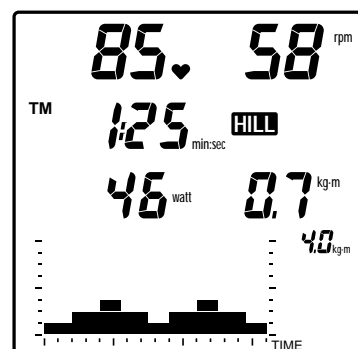

- Press the button to start the program after you set the conditions.
- The LCD changes as in the drawing.
- The hill pattern is shown in the graphic part, and the dot at the far left is blinking. One dot along the vertical axis indicates 0.5 kg-m, while one along the horizontal axis differs in proportion with the preset exercise time. If it is 16 minutes for example, one dot stands for 30 seconds, and if 32 minutes one is 1 minute.
- When the time represented by one dot is over, the dot to the immediate right will start blinking. With the lapse of time, the blinking row will move to the right. The position of the blinking dots determines where you are in the hill pattern.

Note: There is no warm up phase in the "Hill profile training" program.

4 Exercise

- The pedal resistance (torque, kg-m) changes periodically according to the exercise pattern.

5 End Program

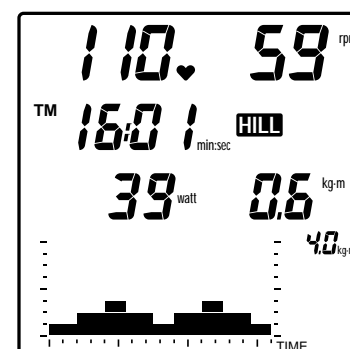

- The buzzer sounds at the specified time and the program completely ends. Review the calorie consumption using the button when you get close to the specified time.
- The LCD returns to the initial screen.

Note 1: There is no cool down phase if you end the "Hill profile training" program when it has reached the end of the exercise time.

Note 2: If you press the button during exercise, the program enters a 5 minute cool down phase and the pedal resistance becomes the minimum 0.5 kg-m. The LCD still displays the content during exercise. The program ends if the 5 minute cool down phase elapses or if the button is pressed.

Exercise Pattern

PRF-1 the Apennines
maximum torque 1.7 kg-m

PRF-2 the Cascades
maximum torque 2.5 kg-m

PRF-3 the Pyrenees
maximum torque 3.0 kg-m

How to make a data card

If you record your training conditions to this "Data Card", you can set the conditions merely by inserting the card into the card inlet of the control unit. You can start a program just by inserting the card and pressing the  button, saving all the button operation process.

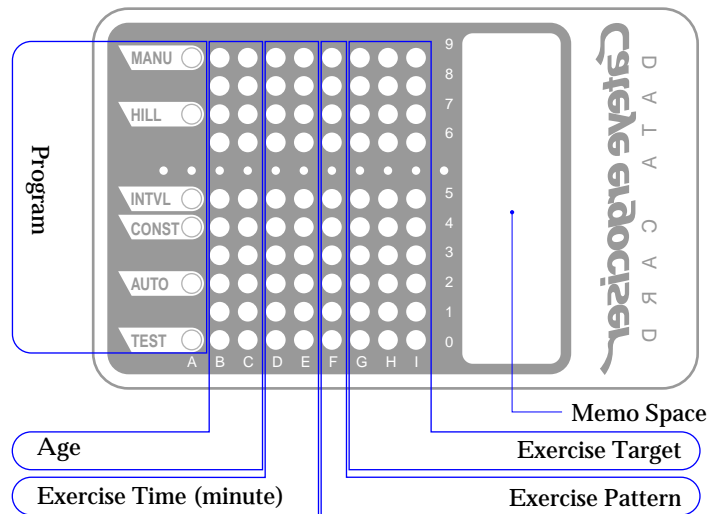

To record your conditions to the data card, scratch off the appropriate silver part on the back of the card with a coin etc. This removal allows the photo scanner in the control unit to detect the position of the exposed part. Now let's make your "Data Card."

NOTE: One Data Card is necessary for each of the desired conditions. You cannot specify two or more conditions on one card.

EXAMPLES OF DATA CARD PROGRAMMING

Three data cards are shown, each with specific programming details:

- For Automatic Training:** Age: 28 years Time: 35 minutes Target Pulse Rate: 130 bpm
- For Manual Training:** Age: 57 years Time: 40 minutes Set Torque: 1.5 kg/m
- For Aerobic PowerMeasurement:** Age: 35 years Weight: 56 kgs. Sex: Female
- For Hill Profile Training:** Age: 45 years Time: 32 minutes Pattern: 3 (The Cascades)

1. Specify Program

- Specify the program in "A".

Note: Though INTVL (= Interval program) is shown on the Data Card, this program cannot be specified on the model EC-1200.

2. Specify Age

- Specify your age in "B" and "C".
 - "B" indicates the first digit of your age, "C" indicates the second.
- Example: Age 35 years
Enter "3" in "B" column
Enter "5" in "C" column

3. Specify Exercise Time

- Specify your exercise time in "D" and "E".
- "D" indicates the first digit of the exercise time, "E" indicates the second.

4. Specify Exercise Pattern

- Specify the exercise pattern in "F" when the "Hill profile training" is selected.
- Choose one of 1 ~ 3.

5. Specify Training Target

- Specify the training target in "G", "H" and "I".
- Automatic Training**
Specify the target pulse rate. "G" indicates the first digit of the value, "H" indicates the second and "I" indicates the third digit.
 - Isopower Training**
Specify the set wattage. "G" indicates the first digit of the wattage, "H" indicates the second, and "I" indicates the third digit.
 - Manual Training**
Specify the set torque value. "H" indicates the first digit of the value, "I" indicates the first decimal place. The program recognizes any "G" setting as invalid.
 - Hill Profile Training**
What you specify in "G", "H", "I" is invalid.

Note 1: When you execute the "Aerobic Power Measurement" with the card, specify your weight in "D", "E" and "F". "D" is the third digit, "E" the second and "F" the first digit. Your sex is specified in "G". "0" indicates female, "1" male.

Note 2: If Interval program is specified on the Data Card, the model EC-1200 will take it as Isopower program.

CAUTIONS ON HANDLING THE DATA CARD

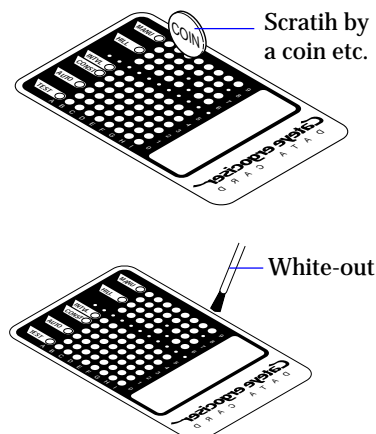

- Treat the card with care. Do not bend or damp the card.
- Scratch only the necessary part of the silver ink. Otherwise the sensor will not read out the data.
- Wipe the residue of the scratched silver ink off the card before inserting the card into the control unit.
- The blank space on the card can be utilized as memo space to enter the programmed data, user's name etc.
- If you have scratched incorrect data, use "white out" to cover the hole. If the light doesn't go through the hole that you have covered up, the card can be used normally.

NOTE: If "ERROR" appears on the LCD when you insert the card, check whether any incorrect or unnecessary point has been scratched out.

Reference

- 1 Handling the pulse (earlobe) sensor
- 2 Troubleshooting
- 3 Handling/Warranty service
- 4 Specifications

1 Handling the pulse(earlobe) sensor

2 Troubleshooting

Precautions

- Firmly clip the pulse sensor to the center of your right or left ear lobe. If you are wearing ear rings remove them.
- When it is cold, massage your earlobe before use to improve blood circulation.
- Try not to change the position of the pulse sensor during the exercise.
- If the **⊖** symbol frequently lights up during use, remove then re-attach the pulse sensor.
- Attach the cable clip to your clothes to prevent excessive swinging of the sensor cable.

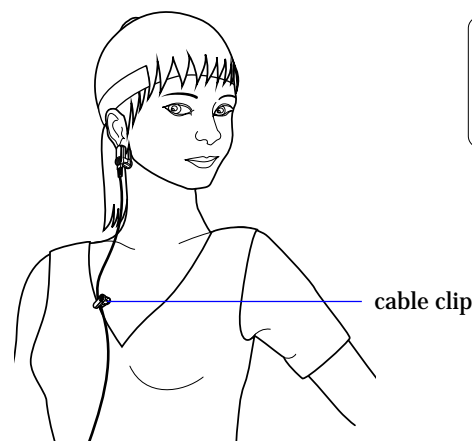

CAUTION: Treat the pulse sensor with care. The cable can be damaged if pulled strongly.



Use of Sensor Clip

- Always clip the pulse sensor to the sensor clip when it is not being used. This sensor clip can also be used to adjust the slack of the cable.

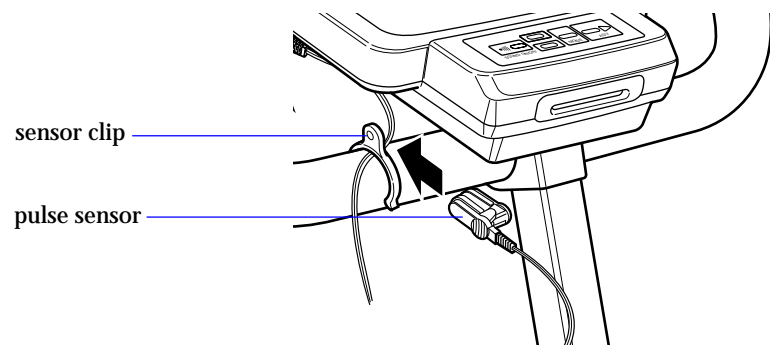

Checking the Pulse Sensor

- You can check the function of the pulse sensor on the LCD screen during the exercise.
- Remove the pulse sensor from your earlobe during exercise, then close it.
- The pulse sensor is normal if the pulse rate drops to zero and the ♥ symbol goes out.
- If the pulse rate does not drop to zero or if the ♥ symbol remains ON, the cable may be disconnected. If the cable proves to be disconnected, replace the pulse sensor with a new one (sold separately).

Troubleshooting

Problems noted in the following chart are not disorders. Prior to seeking repair, read the contents of the entire chart first.

Problem	Item to check	Countermeasure
Display does not appear.	Is the power supply connected?	Connect the AC adaptor correctly. (see page 12)
	Is the power switch on?	Turn the power on.
	Isn't the cable of the AC Adapter damaged?	Replace the AC Adapter if its interior circuit or the cable is damaged.
ERROR or irregular display appears when you insert the data card.	Isn't the data card reversed?	Hold the card yellow arrow side up, and insert to the direction of arrow.
	Didn't you insert the card too quickly?	Insert the card slowly.
	Didn't you specify two or more programs, or open unnecessary holes?	Refer to P.36-37 and specify the program and conditions correctly.
The pulse rate is not displayed, remaining "0".	Is the pulse sensor attached correctly to your earlobe?	Insert the sensor plug securely into the sensor jack, and check the pulse sensor function according to page 40. If the sensor cable proves to be broken, replace the pulse sensor (part #1655210).
	Is the sensor plug completely inserted into the sensor jack?	
The pulse rate increases abnormally.	Is the pulse sensor correctly attached to your earlobe?	Attach the sensor correctly to your earlobe and take care not to swing the sensor or sensor cable during the exercise.
	Isn't the sensor cable damaged?	If the sensor cable proves to be damaged, replace the whole pulse sensor with a new one.
The evaluation of fitness level seems incorrect.	Is the weight unit correct?	Set the weight unit correctly. (see page 8)
	Did you select the correct fitness level evaluation table?	Check the selector switch on the back panel of the control unit. (see page 8)
The program is suspended halfway.	Isn't the upper pulse limit alarm ringing due to the excess of your pulse rate during the exercise?	Input your age correctly to prevent the alarm from ringing unduly.
Buzzer keeps sounding.	Isn't the pulse limit setting too low due to an incorrect age input?	
The pitch sound doesn't ring.	Is the ••••• symbol shown on the LCD?	Press the ••••• button on the control unit to let the ••••• symbol show up.
Clattering noise is heard with the pedal rotation.	Are the pedals firmly attached to the crank? If not, noise may be produced.	Attach the pedals firmly.

Handling/Warranty service

Handling

For longer use of the Ergociser EC-1200, observe the following precautions.

- Do not disassemble the main and control units. In case of problems contact your dealer where the unit was purchased.
- Avoid using the Ergociser EC-1200 in a high temperatures or in high humidity. Also, do not splash the unit with water.
- Handle the pulse sensor carefully. If strongly pulled out the cable may become disconnected.
- When the EC-1200 is not in use, shut the power switch OFF and disconnect the power cord from the outlet.
- Do not wipe the main unit with organic solvents such as thinner, kerosine, gasoline and alcohol. When dirty, wipe the unit with a cloth soaked in a neutral detergent, then wipe well with a dry cloth.
- Do not place the EC-1200 in direct sun light.

Warranty service and parts

- Cat Eye Co., Ltd. guarantees that the Cateye Ergociser™ Model EC-1200 is free from material defects and malfunctions under correct and normal use for three (3) years from the date of purchase. In case there should be defects or malfunctions, Cat Eye will repair or replace the unit or parts, according to the terms and conditions mentioned in the separate Warranty Card.
- If repair service is required, contact your dealer where the unit was purchased.
- The warranty covers only the main unit and the control unit. Accessories such as the pulse sensor or the AC adaptor are not covered.

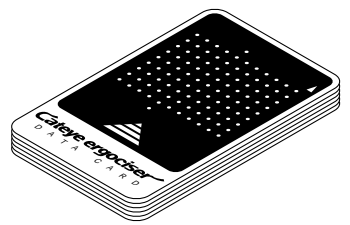
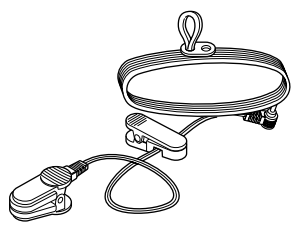
Parts for Replacement	
 <p>Data Card (10 pcs) (Part #7224950)</p>	 <p>Pulse Sensor (Part #1655210)</p>
Optional Parts	

Specifications

Item	Specifications	
Power source	Home AC Power (Use specified AC adapter only.)	
Power consumption	Max. approx. 15 W	
Loading system	Eddy current system	
Speed increasing mechanism	2-step speed increase by chain and timing belt	
Control system	8-bit microcomputer control system	
Display system	Liquid crystal display	
Display functions	Function	Display range
	Pulse rate	50 ~ 199 bpm
	Pedal cadence	20 ~ 199 rpm
	Exercise time	00min.00sec. ~ 99min.59sec.
	Calorie consumption	0 ~ 999 Kcal (Estimated value)
	Load torque	0.5 ~ 4.0 kg·m
	Work rate (wattage)	0 ~ 400 watts
Data input system	Data card (Use specified cards only) and buttons	
Pulse sensor	Earlobe pulse sensor (with special noise reducing system)	
Exercise programs	Program	Specifications
	Aerobic power measurement	Fitness level evaluation by MOU value Applicable range: age of 20 ~ 69 years
	Auto matic training	Exercise under a constant pulse rate Setting range: 60 ~ 180 bpm
	Isopower training	Exercise under a constant load (wattage) Setting range: 25 ~ 200 watts
	Hill profile training	Exercise under one of the 3 patterns of hill profiles
	Manual training	Exercise under a constant pedal resistance (torque) Setting range: 0.5 ~ 4.0 kg·m
	Alarm function	Upper pulse limit alarm: buzzer beeps continuously and pedal torque is reduced to the minimum
Buzzer sound	Pitch sound (120 times/min. cancellable), Upper pulse limit, Confirmation of button function	
User's weight limit	Approx. 286 lbs. (130 kgs)	
Measurement	Handlebar height	31-1/2 ~ 52 inches (800 ~ 1320 mm)
	Saddle height	30-5/16 ~ 46-1/16 inches (770 ~ 1170 mm)
	Length	38-3/16 inches (970 mm)
	Width	21-1/4 inches (540 mm)
Weight	Approx. 62 lbs (28 kgs)	

U.S. Pat. 4775145, Pat. & Design Pat. Pending

*The specifications and design are subject to alteration without notice for improvement purpose.

**"CATEYE™" and "ERGOCISER™" are registered trademarks of CAT EYE CO., LTD.



CATEYE CO., LTD.

2-8-25, Kuwazu, Higashi Sumiyoshi-ku, OSAKA, 546-0041 JAPAN

PHONE: (06) 6719-7781 FAX: (06) 6719-2362